

Australian/New Zealand Standard™

**Specifications for rainwater goods,
accessories and fasteners**

**Part 1: Metal shape or sheet rainwater
goods, and metal accessories and
fasteners**



AS/NZS 2179.1:2014

This Joint Australian/New Zealand Standard was prepared by Joint Technical Committee WS-014, Plumbing and Drainage. It was approved on behalf of the Council of Standards Australia on 29 July 2014 and on behalf of the Council of Standards New Zealand on 25 July 2014.
This Standard was published on 22 August 2014.

The following are represented on Committee WS-014:

Association of Hydraulic Services Consultants Australia
Australian Building Codes Board
Australian Industry Group
Building Officials Institute of New Zealand
Department of Building and Housing, New Zealand
Gas Appliance Manufacturers Association of Australia
Institute of Plumbing Australia
International Copper Association of Australia
Master Plumbers Australia
Master Plumbers, Gasfitters and Drainlayers New Zealand
National Fire Industry Association
Plastics Industry Pipe Association of Australia
Plastics New Zealand
Plumbing Products Industry Group
Water New Zealand
Water Services Association of Australia

Additional Interests:

Australian Steel Institute
Australian Water Association
BlueScope Steel
Department of Commerce WA
Department of Justice, Tas.
Engineers Australia
Housing Industry Association
Insurance Council of Australia
Stormwater Industry Association
Victorian Building Authority

Keeping Standards up-to-date

Standards are living documents which reflect progress in science, technology and systems. To maintain their currency, all Standards are periodically reviewed, and new editions are published. Between editions, amendments may be issued. Standards may also be withdrawn. It is important that readers assure themselves they are using a current Standard, which should include any amendments which may have been published since the Standard was purchased.

Detailed information about joint Australian/New Zealand Standards can be found by visiting the Standards Web Shop at www.saiglobal.com.au or Standards New Zealand web site at www.standards.co.nz and looking up the relevant Standard in the on-line catalogue.

For more frequent listings or notification of revisions, amendments and withdrawals, Standards Australia and Standards New Zealand offer a number of update options. For information about these services, users should contact their respective national Standards organization.

We also welcome suggestions for improvement in our Standards, and especially encourage readers to notify us immediately of any apparent inaccuracies or ambiguities. Please address your comments to the Chief Executive of either Standards Australia or Standards New Zealand at the address shown on the back cover.

This Standard was issued in draft form for comment as DR2 AS/NZS 2179.1.

Australian/New Zealand Standard™

Specifications for rainwater goods, accessories and fasteners

Part 1: Metal shape or sheet rainwater goods, and metal accessories and fasteners

First published as part of AS CS3—1931.
Revised and redesignated in part as AS 2179—1978.
Revised and designated in part as AS 2179—1986.
Revised and redesignated in part as AS/NZS 2179.1:1994.
Second edition 2014.

COPYRIGHT

© Standards Australia Limited/Standards New Zealand

All rights are reserved. No part of this work may be reproduced or copied in any form or by any means, electronic or mechanical, including photocopying, without the written permission of the publisher, unless otherwise permitted under the Copyright Act 1968 (Australia) or the Copyright Act 1994 (New Zealand).

Jointly published by SAI Global Limited under licence from Standards Australia Limited, GPO Box 476, Sydney, NSW 2001 and by Standards New Zealand, Private Bag 2439, Wellington 6140.

ISBN 978 1 74342 820 7

PREFACE

This Standard was prepared by the Joint Standards Australia/Standards New Zealand Committee WS-014, Plumbing and Drainage, to supersede AS/NZS 2179.1:1994.

The objective of this Standard is to provide manufacturers with requirements for determining the fitness for purpose of metal shape or sheet rainwater goods, and metal accessories and fasteners.

The objective of this revision is to provide for the use in rainwater goods, accessories and fasteners of additional coatings using several alloys of aluminium, zinc and magnesium as detailed in AS 1397, *Continuous hot-dip metallic coated steel sheet and strip—Coatings of zinc and zinc alloyed with aluminium and magnesium*, and to ensure compliance with the Australian Building Codes Board protocol for referenced documents.

This Standard is one of three Standards related to rainwater goods, the others being AS 1273, *Unplasticized PVC (UPVC) downpipe and fittings for rainwater*, and AS/NZS 3500.3, *Plumbing and drainage—Stormwater drainage*.

The principal change in this edition is the provision for the addition of aluminium/zinc/magnesium alloy-coated steel.

The terms ‘normative’ and ‘informative’ have been used in this Standard to define the application of the appendix to which they apply. A ‘normative’ appendix is an integral part of a Standard, whereas an ‘informative’ appendix is only for information and guidance.

Statements expressed in mandatory terms in Notes to figures and tables are deemed to be requirements of this Standard.

Notes used in this Standard are of an advisory nature only and are used to give explanation or guidance to the user on recommended considerations or technical procedures, or to provide an informative cross-reference to other documents or publications. Notes to Clauses in this Standard do not form a mandatory part for compliance with this Standard.

PROVISION FOR REVISION

This Standard necessarily deals with existing conditions, but is not intended to discourage innovation or to exclude materials, equipment and methods, which may be developed in the future. Revisions will be made from time to time in view of such developments and amendments to this edition will be made only when absolutely necessary.

CONTENTS

	<i>Page</i>
SECTION 1 SCOPE AND GENERAL	
1.1 SCOPE.....	4
1.2 NORMATIVE REFERENCES	4
1.3 DEFINITIONS.....	5
1.4 DESIGNATION	6
1.5 MARKING	6
SECTION 2 MATERIALS	
2.1 GENERAL.....	8
2.2 ALUMINIUM ALLOYS	8
2.3 ALUMINIUM/ZINC ALLOY-COATED STEEL.....	8
2.4 COPPER AND COPPER ALLOYS.....	9
2.5 ZINC-COATED STEEL	9
2.6 STAINLESS STEEL.....	10
2.7 ZINC.....	10
2.8 ALUMINIUM/ZINC/MAGNESIUM ALLOY-COATED STEEL.....	11
SECTION 3 PATHS TO COMPLIANCE	
3.1 METAL THICKNESS	12
3.2 EAVES GUTTERS.....	12
3.3 BOX GUTTERS	12
3.4 VALLEY GUTTERS.....	12
3.5 DOWNPIPES	13
3.6 RAINHEADS AND SUMPS	14
3.7 EFFECTIVE CROSS-SECTIONAL AREA.....	14
SECTION 4 TESTS	
4.1 GENERAL.....	15
4.2 APPARATUS	15
4.3 VERTICAL LOAD.....	15
4.4 HORIZONTAL LOAD	15
4.5 IMPACT LOAD	16
APPENDICES	
A VERTICAL LOAD TEST.....	17
B HORIZONTAL LOAD TEST.....	22
C IMPACT LOAD TEST	25

STANDARDS AUSTRALIA/STANDARDS NEW ZEALAND

Australian/New Zealand Standard**Specifications for rainwater goods, accessories and fasteners****Part 1: Metal shape or sheet rainwater goods, and metal accessories and fasteners**

SECTION 1 SCOPE AND GENERAL

1.1 SCOPE

This Standard specifies provisions for prepainted metal, metal and organic film/metal laminated shape or sheet rainwater goods, and metal accessories and fasteners.

1.2 NORMATIVE REFERENCES

The following are the normative documents referenced in this Standard:

AS

- | | |
|-----------|---|
| 1290 | Linear measuring instruments used in construction |
| 1290.5 | Part 5: Coated and etched steel measuring tapes |
| 1397 | Continuous hot-dip metallic coated steel sheet and strip—Coatings of zinc and zinc alloyed with aluminium and magnesium |
| 1449—1994 | Wrought alloy steels—Stainless and heat-resisting steel plate, sheet and strip |
| 1566 | Copper and copper alloys—Rolled flat products |
| 1789 | Electroplated zinc (electrogalvanized) coatings on ferrous articles (batch process) |
| 1874 | Aluminium and aluminium alloys—Ingots and castings |
| 1881 | Zinc alloys—Casting ingots and castings—Quality requirements |
| 1897 | Electroplated coatings on threaded components (metric coarse series) |
| 1984 | Vernier callipers (metric series) |
| 2837—1986 | Wrought alloy steels—Stainless steel bars and semi-finished products |
| 3566 | Self-drilling screws for the building and construction industries |
| 3566.1 | Part 1: General requirements and mechanical properties |
| 4100 | Steel structures |
| 4312 | Atmospheric corrosivity zones in Australia |

AS/NZS

- | | |
|------|---|
| 1567 | Copper and copper alloys—Wrought rods, bars and sections |
| 1573 | Copper and copper alloys—Wire for engineering purposes |
| 1734 | Aluminium and aluminium alloys—Flat sheet, coiled sheet and plate |
| 1866 | Aluminium and aluminium alloys—Extruded rod, bar, solid and hollow shapes |

AS/NZS	
1867	Aluminium and aluminium alloys—Drawn tubes
2728	Prefinished/prepainted sheet metal products for interior/exterior building applications—Performance requirements
3500	Plumbing and drainage
3500.3	Part 3: Stormwater drainage
3500.5	Part 5: Housing installations
4680	Hot-dip galvanized (zinc) coatings on fabricated ferrous articles
NCC	National Construction Code
BCA	Volume Two: Building Code of Australia, Class 1 and Class 10 Buildings
ASTM	
A167-99	Standard Specification for Stainless and Heat-Resisting Chromium-Nickel Steel Plate, Sheet, and Strip (2009)
B164	Standard Specification for Nickel-Copper Alloy Rod, Bar, and Wire

1.3 DEFINITIONS

For the purpose of this Standard, the definitions below apply:

1.3.1 Accessories

Include stop ends, support systems, downpipe straps (also known as astragals), downpipe vents, saddle flashing and leaf guarding.

1.3.2 Base metal thickness

Thickness of the steel, excluding the thickness of any coating.

1.3.3 Box gutters

Graded channels located within the perimeter of a building for the conveyance of rainwater.

1.3.4 Downpipes

Vertical or graded (at an angle greater than 15° to the vertical) conduits, with or without a rainhead or sump, for the conveyance of rainwater from a gutter.

1.3.5 Eaves gutters, external

Usually preformed channels for the conveyance of rainwater located along the eaves of a roof external to the fascia line.

1.3.6 Eaves gutters, internal

Usually purpose-made channels for the conveyance of rainwater and included in the design of the roof within the fascia line.

1.3.7 Fasteners

Devices for fixing accessories or rainwater goods by mechanical means (for example screws, rivets, clips and brackets).

1.3.8 Nozzle

The connecting component between the sole of a gutter and a downpipe; also known as a drop or pop.

1.3.9 Rainhead

A collector connected to a downpipe at the end of a gutter, external to the building, that permits a free flow from the end of the gutter.

1.3.10 Rainwater goods

Include eaves, box and valley gutters, downpipes, rainheads, sumps, spreaders, soakers and nozzles.

1.3.11 Soaker

A purpose-made channel or flashing located along the intersection of a roof with the upper edge of a chimney or similar roof penetration.

1.3.12 Spreader

A device fitted to the foot of a downpipe to distribute evenly rainwater onto a roof at a lower level.

1.3.13 Stop end

A shaped piece used to enclose the end of a gutter or capping.

1.3.14 Sump

An internal collector of water from a gutter system for discharge to a connecting downpipe.

1.3.15 Telescoping

Jointing by sliding one length into another.

1.3.16 Valley gutters

Inclined channels placed at the intersecting sloping surfaces of the adjacent roof for the conveyance of rainwater.

1.4 DESIGNATION

Metal rainwater goods shall be designated according to—

- (a) function (e.g. eaves gutter or box gutter);
- (b) material of construction; and
- (c) size.

1.5 MARKING

1.5.1 Rainwater goods

Each length of rainwater goods or packaging shall be clearly marked with—

- (a) manufacturer's trade name or trademark;
- (b) function (e.g. eaves gutter or box gutter);
- (c) material of construction; and
- (d) size.

Where for compliance with this Standard rainwater goods are tested to Appendix A, B or C, the rainwater goods shall be marked with the following:

- (i) The information of Items (a) to (d) above.
- (ii) Demonstration of compliance with Appendix A, B or C of this Standard, as appropriate.

Such markings shall be restricted to internal or rear surfaces, or on fixing legs of rainwater goods, so that appearance is not marred when protective coatings are not specified.

1.5.2 Formed-on-site gutters

Compliance with Clause 1.5.1 of roll-formed on-site gutters shall be indicated on the documentation covering the supply of gutters.

NOTE: Manufacturers making a statement of compliance with this Joint Australian/New Zealand Standard on a product, packaging or promotional material related to that product are advised to ensure that such compliance is capable of being verified.

SECTION 2 MATERIALS

2.1 GENERAL

Metal materials for the manufacture of rainwater goods, accessories and fasteners shall comply with the appropriate clauses of this Section. The minimum base metal thickness for rainwater goods and accessories shall comply with Section 3.

NOTE: For materials made from zinc/aluminium alloy-coated steel and zinc/aluminium/magnesium alloy-coated steel, refer to AS 1397.

Where rainwater goods and accessories, manufactured from more than one material, are components of a system, then contact between such components shall comply with AS/NZS 3500.3, AS/NZS 3500.5 or NCC, Volume Two.

NOTE: Materials selected for rainwater goods should be compatible with those of the upstream roof covering and rainwater goods (see AS/NZS 3500.3 or NCC, Volume Two).

Fasteners, including retained mandrels, shall be durable, corrosion-resistant and compatible with any other material they may be in contact with or receive drainage from.

NOTE: See also AS/NZS 3500.3, AS/NZS 3500.5 or NCC, BCA Volume Two.

2.2 ALUMINIUM ALLOYS

2.2.1 General

Rainwater goods of aluminium alloy may be plain, embossed or clad with an aluminium/zinc alloy, prepainted or anodized.

2.2.2 Rainwater goods

Aluminium alloys for the manufacture of rainwater goods shall be of the 1000, 3000, 5000 or 6000 series complying with AS/NZS 1734, AS/NZS 1866 or AS/NZS 1867, or 400 series complying with AS 1874, as appropriate. The copper content of aluminium alloys shall not exceed 0.25%. Prepainted materials shall also comply with AS/NZS 2728.

2.2.3 Accessories

Aluminium alloys for the manufacture of accessories shall comply with Clause 2.2.2 if not used for castings, or AS 1874 if used for castings.

2.2.4 Fasteners

Materials for the manufacture of fasteners for rainwater goods and accessories of aluminium alloys shall be in accordance with the following:

- (a) Aluminium alloys complying with Clause 2.2.2.
- (b) Stainless steel complying with AS 2837—1986 and ASTM A167-99(2009) Grade 304, Grade 305 or Grade 316.

2.3 ALUMINIUM/ZINC ALLOY-COATED STEEL

2.3.1 General

Rainwater goods of aluminium/zinc alloy-coated steel may be plain or prepainted.

2.3.2 Rainwater goods

Aluminium/zinc alloy-coated steel for manufacture of rainwater goods shall comply with AS 1397 with a minimum coating of Class AZ150. Prepainted materials shall comply with AS/NZS 2728.

2.3.3 Accessories

Aluminium/zinc alloy-coated steel used for accessories shall comply with Clause 2.3.2.

2.3.4 Fasteners

Materials for the manufacture of fasteners for rainwater goods and accessories of aluminium/zinc alloy-coated steel shall be in accordance with the following:

- (a) Aluminium alloys shall comply with Clause 2.2.2.
- (b) Aluminium/zinc alloy-coated steel shall comply with Clause 2.3.2 for sheet metal.
- (c) Aluminium/zinc/magnesium alloy-coated steel shall comply with Clause 2.8.2 for sheet metal.
- (d) Zinc-coated steel shall comply with—
 - (i) Clause 2.5.2 for sheet metal;
 - (ii) AS/NZS 4680 for hot-dip galvanized (zinc) coatings on fabricated ferrous articles;
 - (iii) AS 1789 for minimum zinc classification code of Fe/Zn 12; and
 - (iv) AS 1897 for service condition 3 (severe), with chromate conversion coating type C (iridescent).
- (e) Self-drilling screws shall comply with AS 3566.1, with a minimum Class 3 coating.

2.4 COPPER AND COPPER ALLOYS

2.4.1 General

The temper of copper and copper alloys shall be appropriate to, and most practicable for, the necessary forming operations.

2.4.2 Rainwater goods

Copper and copper alloys used for rainwater goods shall comply with AS 1566.

2.4.3 Accessories

Copper and copper alloys used for accessories shall comply with AS 1566.

2.4.4 Fasteners

Fasteners for rainwater goods and accessories of copper and copper alloys shall comply with AS/NZS 1567 or AS/NZS 1573.

2.5 ZINC-COATED STEEL

2.5.1 General

Rainwater goods of zinc-coated steel may be plain, prepainted or laminated organic coated.

2.5.2 Rainwater goods

Zinc-coated steel used for rainwater goods shall comply with materials specified in AS 1397 with a minimum coating of Class Z275. Prepainted and laminated organic-coated materials shall also comply with AS/NZS 2728.

2.5.3 Accessories

Zinc-coated steel used for accessories shall comply with Clause 2.5.2.

2.5.4 Fasteners

Materials for the manufacture of fasteners for rainwater goods and accessories of zinc-coated steel shall be in accordance with Clause 2.3.4.

2.6 STAINLESS STEEL

2.6.1 Rainwater goods

Stainless steel for the manufacture of rainwater goods shall comply with the atmospheric classifications of AS 4312 for the intended installation and the following grades of AS 1449—1994:

- (a) For mild (rural) or moderate (urban/light industrial), Grade 301, 302 304 or 316.
- (b) For severe industrial or very severe, Grade 316.

Prepainted materials shall also comply with AS/NZS 2728.

2.6.2 Accessories

Stainless steel for the manufacture of accessories shall comply with Clause 2.6.1.

2.6.3 Fasteners

Materials for the manufacture of fasteners for rainwater goods and accessories of stainless steel shall be in accordance with Table 2.1.

TABLE 2.1
STAINLESS STEEL FASTENERS

Rainwater goods and accessories, grade to AS 1449—1994	Fasteners
301, 302, or 304	AS 2837—1986 ASTM A167-99(2009) Grade 305 ASTM B164 alloy 400 (Monel)
316	ASTM A167-99(2009) Grade 305 ASTM B164 alloy 400 (Monel)

2.7 ZINC

2.7.1 Rainwater goods

Zinc material for the manufacture of rainwater goods shall be zinc alloy containing copper or titanium, or both. The copper content shall not exceed 0.8% and the titanium content shall not exceed 0.2%. Only hard to half-hard material shall be used.

2.7.2 Accessories

Zinc material may be used for accessories, provided—

- (a) components fabricated wholly of zinc are fabricated from zinc alloy complying with Clause 2.7.1; and
- (b) zinc alloy for pressure diecast components complies with AS 1881.

2.7.3 Fasteners

Materials for the manufacture of fasteners for rainwater goods and accessories of zinc material shall be in accordance with the following:

- (a) Aluminium alloys shall comply with Clause 2.2.2.
- (b) Stainless steel shall be as given in Table 2.1.
- (c) Zinc-coated steel shall comply with Clause 2.3.4(d).

2.8 ALUMINIUM/ZINC/MAGNESIUM ALLOY-COATED STEEL

2.8.1 General

Rainwater goods of aluminium/zinc/magnesium alloy-coated steel may be plain or prepainted.

2.8.2 Rainwater goods

Aluminium/zinc/magnesium alloy-coated steel for the manufacture of rainwater goods shall comply with AS 1397 with a minimum coating of Class AM125. Prepainted materials shall comply with AS/NZS 2728 with a minimum coating of Class AM100.

2.8.3 Accessories

Aluminium/zinc/magnesium alloy-coated steel for the manufacture of accessories shall comply with Clause 2.8.2.

2.8.4 Fasteners

Materials for the manufacture of fasteners for rainwater goods and accessories of aluminium/zinc/magnesium alloy-coated steel shall be in accordance with Clause 2.3.4.

SECTION 3 PATHS TO COMPLIANCE

3.1 METAL THICKNESS

The minimum base metal thickness for rainwater goods and accessories, for a particular application, shall comply with this Section.

3.2 EAVES GUTTERS

3.2.1 Provisions

The effective cross-sectional area and minimum base metal thickness of shape or sheet for eaves gutters, stop ends and flashing saddles with sole width equal to or less than 200 mm shall be as specified in Table 3.1.

The effective cross-sectional area and minimum base metal thickness of shape or sheet for eaves gutters and gutter support systems not covered in Table 3.1 shall be determined for compliance with this Standard in accordance with Section 4.

TABLE 3.1
EAVES GUTTERS WITH SOLE WIDTH EQUAL TO OR LESS THAN 200 mm

Effective cross-sectional area mm ²	Minimum base metal thickness of shape or sheet for eaves gutters and accessories mm					
	Zinc-coated steel	Aluminium/zinc or aluminium/zinc/magnesium alloy-coated steel	Copper and copper alloys	Aluminium alloys	Stainless steels	Zinc
≤10 000	0.50 (G300) or 0.42 (G550)	0.50 (G300) or 0.42 (G550)	0.55	0.70	0.45	0.70
>10 000 ≤20 000	0.60 (G300) or 0.48 (G550)	0.60 (G300) or 0.48 (G550)	0.70	0.70	0.55	0.90

NOTE: The designations in parentheses are grades according to AS 1397.

3.3 BOX GUTTERS

The minimum base metal thickness for each box gutter and support system shall be determined in accordance with Clause 4.3 and Appendix A.

3.4 VALLEY GUTTERS

The minimum base metal thickness of shape or sheet for valley gutters of widths equal to or less than 600 mm with a continuous support system shall be as specified in Table 3.2.

The minimum base metal thickness of shape or sheet of valley gutters not covered in Table 3.2 shall be determined for compliance with this Standard in accordance with Clause 4.3 and Appendix A.

TABLE 3.2
VALLEY GUTTERS WITH WIDTH EQUAL TO OR LESS
THAN 600 mm AND CONTINUOUS SUPPORT SYSTEM

millimetres

Minimum base metal thickness of shape or sheet for valley gutters					
Zinc-coated steel	Aluminium/zinc or aluminium/zinc/magnesium alloy-coated steel	Coppers and copper alloys	Aluminium alloys	Stainless steel	Zinc
0.50 (G300) or 0.42 (G550)	0.50 (G300) or 0.42 (G550)	0.55	0.55	0.45	0.70

NOTE: The designations in parentheses are grades according to AS 1397.

3.5 DOWNPIPES

The minimum base metal thickness of vertical or graded downpipes of cross-sectional areas less than 75 000 mm² shall be as specified in Table 3.3 or 3.4, as appropriate.

The minimum base metal thickness of vertical or graded downpipes not covered in Table 3.3 or 3.4 shall be determined for compliance with this Standard in accordance with Clause 4.5 and Appendix C.

TABLE 3.3
CIRCULAR—VERTICAL OR GRADED DOWNPIPES OF CROSS-SECTIONAL
AREAS LESS THAN 75 000 mm²

millimetres

Nominal size, diameter*		Minimum base metal thickness of shape or sheet for downpipes					
Vertical[†]	Graded[‡]	Zinc-coated steel (G 300)	Aluminium/zinc or aluminium/zinc/magnesium-coated steel (G 300)	Copper and copper alloys	Aluminium alloys[§]	Stainless steel	Zinc
50	50	0.40	0.40	0.55	0.55	0.40	0.80
65	65	0.40	0.40	0.55	0.55	0.40	0.80
75	75	0.40	0.40	0.55	0.55	0.40	0.80
100	100	0.40	0.40	0.55	0.55	0.40	0.80
125	—	0.50	0.50	0.70	0.70	0.50	0.90
140	—	0.50	0.50	0.70	0.70	0.50	0.90
150	—	0.50	0.50	0.70	0.70	0.50	0.90
200	—	0.70	0.70	0.90	0.80	0.70	1.00
250	—	0.70	0.70	1.00	0.90	0.70	1.20
300	—	0.70	0.70	1.00	1.00	0.70	1.20

* Dimension may be less at one end to permit telescoping

[†] Cross-sectional area less than 75 000 mm²

[‡] Cross-sectional area less than 10 000 mm²

[§] For yield strength of not less than 180 MPa

NOTE: The designation in parenthesis is the grade according to AS 1397.

TABLE 3.4
RECTANGULAR OR SQUARE—VERTICAL OR GRADED DOWNPIPES OF
CROSS-SECTIONAL AREAS LESS THAN 75 000 mm²

Nominal size, breadth × width *		Minimum base metal thickness					
Vertical [†]	Graded [‡]	Zinc-coated steel (G 300)	Aluminium/zinc or aluminium/zinc/magnesium alloy-coated steel (G 300)	Copper and copper alloys	Aluminium alloys [§]	Stainless steel	Zinc
75 × 50	75 × 50	0.40	0.40	0.55	0.55	0.40	0.80
70 × 70	75 × 70	0.40	0.40	0.55	0.55	0.40	0.80
100 × 50	100 × 50	0.40	0.40	0.55	0.55	0.40	0.80
100 × 75	100 × 75	0.40	0.40	0.55	0.55	0.40	0.80
100 × 100	—	0.50	0.50	0.70	0.70	0.50	0.90
150 × 100	—	0.50	0.50	0.70	0.70	0.50	0.90
150 × 150	—	0.70	0.70	0.80	0.80	0.70	1.0
200 × 200	—	0.70	0.70	1.0	1.0	0.70	1.2
250 × 250	—	0.70	0.70	1.2	1.2	0.70	1.2

* Dimension may be less at one end to permit telescoping

† Cross-sectional area less than 75 000 mm²

‡ Cross-sectional area less than 10 000 mm²

§ For yield strength of not less than 180 MPa

NOTE: The designation in parenthesis is the grade according to AS 1397.

3.6 RAINHEADS AND SUMPS

The minimum base metal thickness of rainheads and sumps shall be not less than the associated box gutter or downpipe.

3.7 EFFECTIVE CROSS-SECTIONAL AREA

The effective cross-sectional area (to the nearest 100 mm²) for each nominal size of eaves gutter, valley gutter and downpipe shall be supplied. The effective cross-sectional area for each shall be as follows:

- (a) For an eaves gutter and support system—
- (i) with external brackets, the cross-sectional area beneath a line not less than 10 mm below the overflow (e.g. front bead, gutter back or bottom of overflow slots); or
 - (ii) with internal brackets, as for Item (i) less the allowance for the effects of the brackets.

NOTES:

- 1 AS/NZS 3500.3 provides a method for the sizing of eaves gutters, which is based on research using eaves gutters with external brackets.
 - 2 Internal brackets increase the potential for debris collection.
- (b) For a valley gutter, the cross-sectional area beneath a line not less than 15 mm below the top edge or bead (also known as freeboard).
- (c) For a circular downpipe, the cross-sectional area.
- (d) For a rectangular or square downpipe, the cross-sectional area times 0.9.

SECTION 4 TESTS

4.1 GENERAL

One or more of the tests set out in Appendices A, B and C shall be used to demonstrate the compliance of a gutter or downpipe and support system with the appropriate provisions specified in Section 3.

4.2 APPARATUS

The apparatus for each performance test shall comply with Appendices A, B or C, whichever is applicable.

4.3 VERTICAL LOAD

When tested in accordance with Appendix A, the test specimen of a gutter or graded downpipe and its support system shall comply with the following:

- (a) The strength limit state shall sustain the test load for 5.0 +1, –0 min, irrespective of any permanent deformation.
- (b) The serviceability limit state shall sustain the test load for 5.0 +1, –0 min, with a maximum deflection not greater than one hundredth of the distance between the centre-lines of adjacent supports of the support system (l_{ss}), in millimetres. 5.0 +1, –0 min after removal of the test load, the serviceability limit state shall have—
 - (i) a residual deflection not greater than $0.001l_{ss}$; and
 - (ii) no permanent local deformation, fracture or other failure.

NOTES:

- 1 Limits on residual deflection have been included to preserve the appearance of rainwater goods and to minimize ponding. Residual deflection may be difficult, however, to determine reliably because of frictional effects and the like. Techniques performed to improve the reliability of the measurement, such as light tapping of the test specimen, are permissible provided it can be demonstrated that such techniques serve only to settle it to its rest position.
- 2 The location of maximum deflection may not necessarily coincide with the position of maximum deformation. Consideration should be given to the application of the concentrated load directly over a support or mid-span.

4.4 HORIZONTAL LOAD

When tested in accordance with Appendix B, the test specimen of an eaves gutter or graded downpipe and its support system shall have—

- (a) deflections not greater than given in Table 4.1; and
- (b) no permanent local deformation, fracture or other failure.

TABLE 4.1
MAXIMUM DEFLECTION

Rainwater goods	Maximum deflection mm	
	With test load applied	After removal of the test load
Eaves gutter or graded downpipe and the respective support system	50	10

4.5 IMPACT LOAD

When tested in accordance with Appendix C, the test specimen of a vertical or graded downpipe shall sustain the impact load with a measured permanent deformation not greater than 50% of—

- (a) the diameter, for circular cross-sections;
- (b) a side, for square cross-sections; or
- (c) each side of a different length, for rectangular cross-sections.

APPENDIX A
VERTICAL LOAD TEST
(Normative)

A1 SCOPE

This Appendix sets out the method for testing the resistance to vertical loads of a gutter or a graded downpipe and its support system.

A2 PRINCIPLE

The appropriate test load is applied to the test specimen to determine that—

- (a) for a strength limit state, it is sustained without loss of structural integrity; and
- (b) for a serviceability limit state, it is sustained with acceptable deflection and distortion.

A3 DEFINITIONS

For the purpose of this Appendix, the definitions below apply.

A3.1 Concentrated load

A load applied to the test specimen, in accordance with this Standard, AS/NZS 3500.3 or AS/NZS 3500.5, at any point along the sole of a gutter or the crown of a graded downpipe and distributed over an area of—

- (a) 350 mm² for determination of bending moments or shear forces; or
- (b) 10 000 mm² for determination of local effects (e.g. punching and crushing).

A3.2 Dead load (*G*)

The load imposed by the rainwater goods and the support system and calculated from known or design dimensions.

A3.3 Design load

A load that is equal to the product of the appropriate live load (see Table A2) and the respective load factor (see Paragraph A3.5) as given in Table A1.

TABLE A1
DESIGN LOADS

Rainwater goods	Design loads	
	Strength limit state	Serviceability limit state
Eaves gutter and its support system with sole width—		
(a) ≤200 mm	$1.25G + 1.5Q_1$	$G + 0.70Q_1$
(b) >200 mm	$1.25G + 1.5Q_2$	$G + 0.70Q_2$
Box and valley gutter and its support system	$1.25G + 1.5Q_3$ or $1.5Q_4^*$	$G + 0.7Q_3$ or $0.7Q_4^*$
Downpipe and its support system—		
(a) vertical	NA	NA
(b) graded	$1.25G + 1.5Q_2$	$G + 0.7Q_2$

* Adopt the more adverse effect

NA = not applicable

A3.4 Live load

The appropriate concentrated load, or uniformly distributed load or both, for non-trafficable and trafficable applications as given in Table A2.

TABLE A2
LIVE LOADS

Rainwater goods	Live load				
	Application				
	Quantity symbol	Non-trafficable		Trafficable	
		Concentrated load kN	Uniformly distributed load kPa	Concentrated load kN	Uniformly distributed load kPa
Eaves gutter and its support system with sole width—					
(a) ≤200 mm	Q_1	N/A	Filled with water*	—	—
(b) >200 mm	Q_2	1.1	Filled with water*	—	—
Box gutter and its support system	Q_3	—	—	1.8	N/A
	Q_4	—	—	N/A	Filled with water* or uniformly distributed load ^{†‡}
Valley gutter and its support with clear width—					
	(a) ≤100 mm	Q_3	N/A	N/A	—
	(b) >100 mm	Q_3	1.1	N/A	1.8
	Q_4	N/A	Filled with water*	N/A	Filled with water* or uniformly distributed load ^{†‡}
Graded downpipe and its support system	Q_2	1.1	Filled with water*	—	—

N/A = not applicable

* Filled to the point of first overflow (i.e. the lowest edge or the bottom of overflow slots)

† Adopt the more adverse effect

‡ In Australia, 1.5 kPa for Class 1 buildings and associated Class 10 buildings or 2.0 kPa for all other buildings. (Class 1 and Class 10 building as defined in *the National Construction Code, BCA Volume Two*); in New Zealand, 1.5 kPa for residential buildings or 2.0 kPa for all other buildings

A3.5 Load factor

A factor, which a live load is multiplied by, to determine a design load and is equal to—

- 1.5 for the strength limit state; and
- 0.7 for the serviceability limit state.

A3.6 Test load

A load that is applied to the test specimen and equal to the product of the appropriate design load and, unless a reliability assessment shows that a lesser value is valid, the appropriate variability factor as given in Table A3.

A3.7 Uniformly distributed load

A load applied to the test specimen along the sole of a gutter or the crown of a graded downpipe.

TABLE A3
VARIABILITY FACTOR

Number of test specimens to be tested	Variability factor	
	Strength limit state	Serviceability limit state
1	1.5	1.2
2	1.4	1.2
3	1.3	1.2
4	1.3	1.1
5	1.3	1.1
10	1.2	1.1

NOTE: The variability factors have been adopted from AS 4100.

A4 APPARATUS

The following apparatus is required:

- (a) *Support rig* A rig of adequate strength and rigidity that shall not affect the performance of the test specimen or change its mode of failure.

NOTE: The strength limit tests are intended to assess the resistance to collapse from walking in a gutter, other than eaves gutter with a sole width equal to or less than 200 mm, or on a graded downpipe and its support system.

- (b) *Loading system* A system to enable a test load to be applied to the test specimen at either—
- the sole of a gutter; or
 - the crown of a graded downpipe.

Application of a test load shall be by means of a pad of elastomeric or similar material with a hardness of 30 ± 3 IRHD and a thickness of 50 ± 2 mm backed by a disc of steel $12 +2, -0$ mm thick. The plan dimensions of the steel disc shall be the same as the pad (see Paragraphs A3.1 and A3.7).

NOTE: The thickness of the elastomeric or similar material may be made up of an appropriate number of layers equal to or greater than 10 mm thick. The layers need not be connected together, but each should be of the correct hardness and plan dimensions.

- (c) *Measuring devices* The measuring devices shall be capable of measuring to an accuracy of not less than—
- ± 0.5 mm, for deflections and local effects; and
 - $\pm 5\%$, for loads.

NOTE: An accuracy of 5% would normally be achieved by means of a device capable of measuring to an accuracy of $\pm 1\%$ of full scale.

- (d) *Clock* graduated at intervals not greater than 5 s.

A5 TEST SPECIMEN

The test specimen shall consist of either an actual system, or a full-scale model of a section of gutter or downpipe and its support system with a length of not less than 3.5 times the distance between the centre-lines of the adjacent supports of the support system (l_{ss}).

A6 PROCEDURE

The procedure shall be as follows:

- (a) Mount the test specimen in the supporting rig so that the appropriate test loads can be applied by the loading system and the resulting deflection measured by the measuring device.

Measure and record—

- (i) the initial deflection of the test specimen prior to the application of the test load, in millimetres; and
- (ii) the distance between the centre-lines of the adjacent supports of the support system (l_{ss}), in millimetres.
- (b) Apply the test load appropriate to the design load for the limit states, as follows:
- (i) For the strength limit state, maintain the test load for 5.0 +1, -0 min and record its—
- (A) magnitude, in kilonewtons or kilopascals, or both; and
- (B) the period of application, in minutes.
- (ii) For the serviceability limit state:
- (A) Repeat Step (A) of Item (b)(i).
- (B) Measure and record the maximum residual deflection of the test specimen, in millimetres.
- (C) Remove the test load.
- (D) After 5.0 +1, -0 min—
- (1) measure and record the maximum residual deflection of the test specimen, in millimetres; and
- (2) inspect the test specimen and record any permanent local deformation, fracture or other failure.

A7 REPORT

The test report shall include the following:

- (a) For the test specimen:
- (i) The rainwater goods, type, cross-section dimensions and thickness.
- (ii) The support system and—
- (A) whether it is—
- (1) non-trafficable or trafficable; or
- (2) discontinuous or continuous.
- (B) The distance between the centre-lines of adjacent supports of the support system (l_{ss}), in millimetres.
- (C) The description and dimensions.
- (b) For the strength limit state:
- (i) The test load, magnitude, in kilonewtons or kilopascals, or both, and the period of application, in minutes.
- (ii) Whether the test specimen sustained the test load irrespective of any permanent deformation.

- (c) For the serviceability limit state:
 - (i) As for Item (b)(i).
 - (ii) The maximum measured and allowable ($0.01l_{ss}$) deflections, in millimetres.
 - (iii) The maximum measured and allowable ($0.001l_{ss}$) residual deflections, in millimetres.
 - (iv) Any observed permanent local deformation, fracture or other failure.
- (d) Reference to this test method (i.e. AS/NZS 2179.1, Appendix A).
- (e) Whether the test is a pass or fail with respect to serviceability limit state for both deflection and permanent deformation, and the strength limit state for permanent deformation, as specified in Clause 4.3.

APPENDIX B
HORIZONTAL LOAD TEST
(Normative)

B1 SCOPE

This Appendix sets out the method for testing the resistance to horizontal loads of an eaves gutter or graded downpipe and its support system.

B2 PRINCIPLE

The appropriate test load is applied to a test specimen to determine that it is sustained with acceptable deflections and distortions.

B3 APPARATUS

The following apparatus is required:

- (a) *Test rig* A rig used for the horizontal load test.
NOTE: A typical test rig is shown in Figure B1.
- (b) *Supporting rig* A rig of adequate strength and rigidity. The supporting rig shall not affect the performance of the test specimen or change its mode of failure.
- (c) *Loading system* A system to enable a test load of not greater than 0.5 kN to be applied to the test specimen at either—
 - (i) the upper edge of the unsupported side of an eaves gutter; or
 - (ii) the springline of a graded downpipe.

Application of a test load shall be by means of a pair of force legs made of rigid material, 300 ± 2 mm apart, 35 ± 1 mm wide and at an angle of $15 \pm 2^\circ$.

NOTE: Suitable rigid materials include hardwood, steel and aluminium.

- (d) *Measuring devices* The measuring devices shall be capable of measuring to an accuracy of not less than—
 - (i) ± 0.5 mm, for deflections and local effects; and
 - (ii) $\pm 5\%$, for loads.
NOTE: An accuracy of 5% would normally be achieved by means of a device capable of measuring to an accuracy of $\pm 1\%$ of full scale.
- (e) *Clock* graduated at intervals not greater than 5 s.

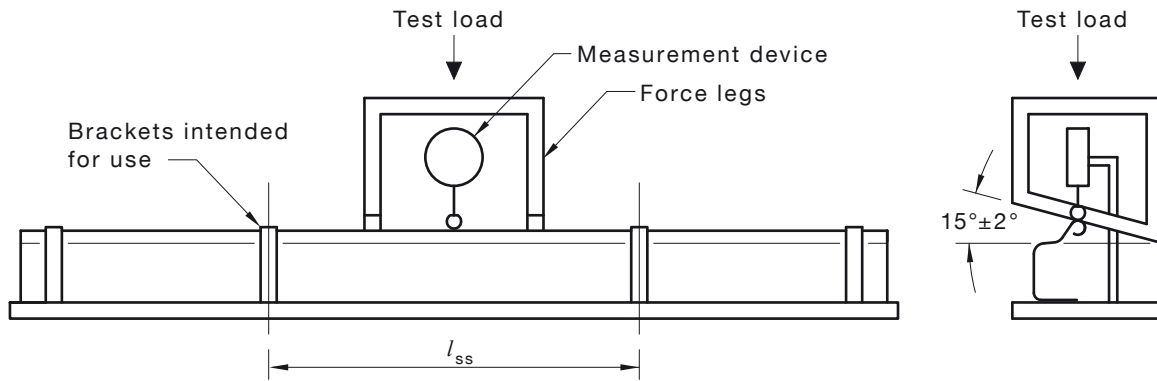

FIGURE B1 TYPICAL TEST RIG FOR HORIZONTAL LOAD TEST

B4 TEST SPECIMEN

The test specimen shall consist of either an actual system, or a full-scale model of a section of gutter or downpipe and its support system with a length of not less than 3.5 times the distance between the centre-lines of the adjacent supports of the support system (l_{ss}).

B5 PROCEDURE

The procedure shall be as follows:

- (a) Mount the test specimen in the supporting rig so that the appropriate test load can be applied by the loading system and the resulting deflection measured by the measuring device.
Measure and record the initial deflection of the test specimen prior to the application of the test load, in millimetres.
- (b) Apply to the test specimen a test load of—
 - (i) $0.3 +0.1, -0$ kN at a point $15 +10, -5$ mm from the top of the unsupported side of an eaves gutter and midway between adjacent supports of its support system; or
 - (ii) $0.3 +0.1, -0$ kN at a point on the springline of a graded downpipe and midway between adjacent supports of its support system.
- (c) Maintain the test load for $5.0 +1, -0$ min and record its—
 - (i) magnitude, in kilonewtons; and
 - (ii) period of application, in minutes.
- (d) Measure and record the maximum deflection of the test specimen, in millimetres.
- (e) Remove the test load and after $5.0 +1, -0$ min—
 - (i) measure and record the maximum residual deflection of the test specimen, in millimetres; and
 - (ii) inspect the test specimen and record any permanent local deformation, fracture or other failure.

B6 REPORT

The report shall include the following:

- (a) For the test specimen—
 - (i) the rainwater goods, type, cross-sectional dimensions and thickness; and
 - (ii) the support system, description and dimensions.
- (b) For the test load—
 - (i) the magnitude, in kilonewtons; and
 - (ii) the period of application, in minutes.
- (c) The maximum measured and allowable (50) deflections, in millimetres.
- (d) The maximum measured and allowable (10) residual deflections, in millimetres.
- (e) Any observed permanent local deformation, fracture or other failure.
- (f) Reference to this test method (i.e. AS/NZS 2179.1, Appendix B).
- (g) Whether the test is a pass or fail with respect to both deflection and permanent deformation, as specified in Clause 4.4.

APPENDIX C
IMPACT LOAD TEST
(Normative)

C1 SCOPE

This Appendix sets out the method for testing the resistance to impact loads of a vertical or graded downpipe.

C2 PRINCIPLE

The test load is applied to the test specimen to determine that it is sustained with acceptable permanent deformation.

C3 APPARATUS

The following apparatus is required:

- (a) *Test rig* for the impact load test.
NOTE: A typical test rig is shown in Figure C1.
- (b) *Impactor* with a mass of 2.0 ± 0.1 , 3.0 ± 0.1 or 4.0 ± 0.1 kg and a cross-sectional area not greater than twice that of the impact head. The vertical drop of the impactor shall be as given in Table C1.

TABLE C1
IMPACTOR

Mass (<i>M</i>) kg	Vertical drop (<i>H</i>) m
2.0 ± 0.1	4.0 ± 0.1
3.0 ± 0.1	2.7 ± 0.1
4.0 ± 0.1	2.0 ± 0.1

- (c) *Impact head* fitted with elastomeric or similar material, 100 ± 2 mm diameter, 50 ± 2 mm thick and a hardness of 30 ± 3 IRHD.
- (d) *Outside vernier callipers*, as specified in AS 1984, to suit the diameter of the test specimen.
- (e) *Steel measure tape*, as specified in AS 1290.5.

C4 TEST SPECIMEN

The test specimen shall consist of an actual downpipe with a length of not less than 1000 mm.

C5 PROCEDURE

The procedure shall be as follows:

- (a) Measure and record the outside diameter or the side length(s) and the base metal thickness of the test specimen, in millimetres.
- (b) Raise the impactor to its maximum height and mount the test specimen in the test rig so that, at impact, the impactor is not be within 500 mm from a free end and point of impact of any previous tests.

- (c) For the mass of the impactor, determine from Table C1 the vertical drop and lower the impactor to this position above the test specimen. Measure and record the distances between the impactor and test specimen, in metres.
- (d) Release the impactor and allow it to fall freely onto the test specimen.
- (e) Raise the impactor, remove the test specimen from the test rig, and measure and record the permanent deformation, in millimetres.
- (f) For rectangular test specimens, repeat Steps (a) to (e) for the other side length.

NOTE: Values for H and M are given in Table C1.

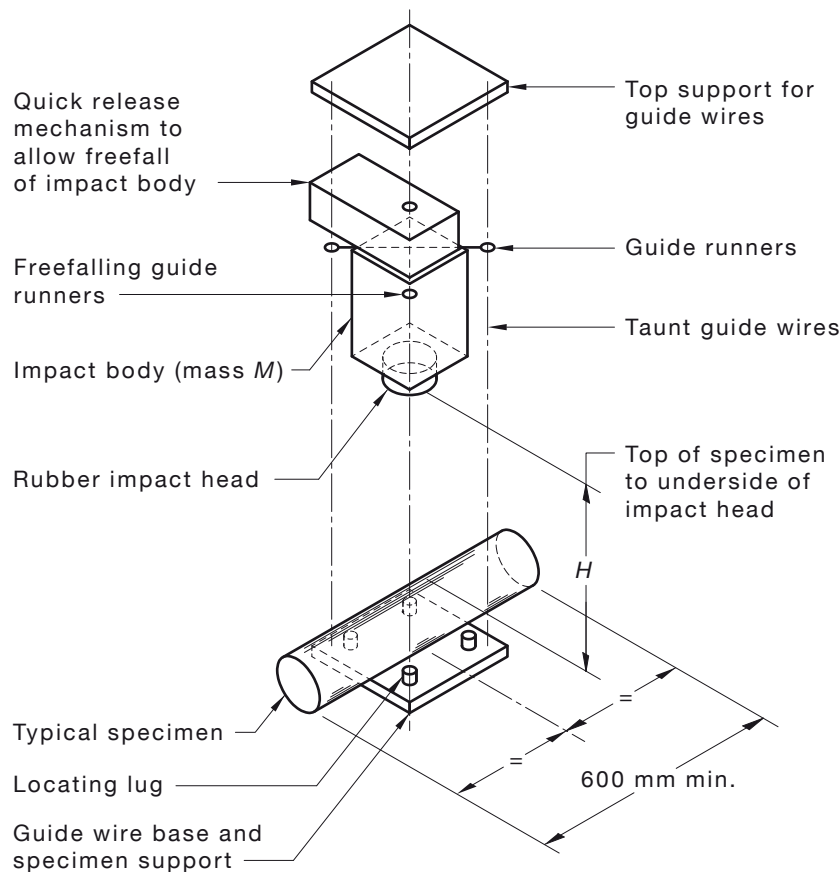

FIGURE C1 TYPICAL TEST RIG FOR IMPACT LOAD TEST

C6 REPORT

The report shall include the following:

- (a) For the test specimen—
 - (i) the materials, cross-sectional dimensions and thickness; and
 - (ii) the percentage of permanent deformation in relation to the deformed dimension, or for rectangular cross-sections, the dimensions.
- (b) The mass of the impactor, in kilograms, and the vertical drop, in metres.
- (c) A reference to this test method (i.e. AS/NZS 2179.1, Appendix C).
- (d) Whether the test is a pass or fail with respect to permanent deformation as specified in Clause 4.5.

NOTES

NOTES

Standards Australia

Standards Australia is an independent company, limited by guarantee, which prepares and publishes most of the voluntary technical and commercial standards used in Australia. These standards are developed through an open process of consultation and consensus, in which all interested parties are invited to participate. Through a Memorandum of Understanding with the Commonwealth government, Standards Australia is recognized as Australia's peak national standards body.

Standards New Zealand

The first national Standards organization was created in New Zealand in 1932. The Standards Council of New Zealand is the national authority responsible for the production of Standards. Standards New Zealand is the trading arm of the Standards Council established under the Standards Act 1988.

Australian/New Zealand Standards

Under a Memorandum of Understanding between Standards Australia and Standards New Zealand, Australian/New Zealand Standards are prepared by committees of experts from industry, governments, consumers and other sectors. The requirements or recommendations contained in published Standards are a consensus of the views of representative interests and also take account of comments received from other sources. They reflect the latest scientific and industry experience. Australian/New Zealand Standards are kept under continuous review after publication and are updated regularly to take account of changing technology.

International Involvement

Standards Australia and Standards New Zealand are responsible for ensuring that the Australian and New Zealand viewpoints are considered in the formulation of international Standards and that the latest international experience is incorporated in national and Joint Standards. This role is vital in assisting local industry to compete in international markets. Both organizations are the national members of ISO (the International Organization for Standardization) and IEC (the International Electrotechnical Commission).

Visit our web sites

www.standards.org.au

www.standards.co.nz



GPO Box 476 Sydney NSW 2001
Phone (02) 9237 6000
Fax (02) 9237 6010
Email mail@standards.org.au
Internet www.standards.org.au
SAI Global Customer Service
Phone 13 12 42
Fax 1300 65 49 49
Email sales@saiglobal.com



Level 6
8 Gilmer Terrace Wellington 6011
(Private Bag 2439 Wellington 6140)
Freephone 0800 782 632
Phone (04) 498 5990
Fax (04) 498 5994
Email enquiries@standards.co.nz
Website www.standards.co.nz