



Pliable building membranes and underlays

Part 2: Installation



This Australian Standard® was prepared by Committee BD-058, Thermal Insulation. It was approved on behalf of the Council of Standards Australia on 27 September 2016. This Standard was published on 2 May 2017.

The following are represented on Committee BD-058:

- Aluminium Foil Insulation Association
 - Australasian Fire and Emergency Service Authorities Council
 - Australian Building Codes Board
 - Australian Cellulose Insulation Manufacturers Association
 - Australian Professional Thermography Association
 - Community Energy Network
 - Consumers Federation of Australia
 - Council of Textile and Fashion Industries of Australia
 - CSIRO
 - Curtin University of Technology
 - Electrical Regulatory Authorities Council
 - Housing Industry Association
 - Insulation Australasia
 - Insulation Contractors Association of Australia NSW
 - Insulation Council of Australia and New Zealand
 - Master Builders Australia
 - Plastics and Chemicals Industries Association
 - Pliable Membranes Association of Australia and New Zealand
 - Polyester Insulation Manufacturers Association
 - Recessed Luminaire Enclosure Association of Australia
-

This Standard was issued in draft form for comment as DR AS 4200.2:2015.

Standards Australia wishes to acknowledge the participation of the expert individuals that contributed to the development of this Standard through their representation on the Committee and through the public comment period.

Keeping Standards up-to-date

Australian Standards® are living documents that reflect progress in science, technology and systems. To maintain their currency, all Standards are periodically reviewed, and new editions are published. Between editions, amendments may be issued.

Standards may also be withdrawn. It is important that readers assure themselves they are using a current Standard, which should include any amendments that may have been published since the Standard was published.

Detailed information about Australian Standards, drafts, amendments and new projects can be found by visiting www.standards.org.au

Standards Australia welcomes suggestions for improvements, and encourages readers to notify us immediately of any apparent inaccuracies or ambiguities. Contact us via email at mail@standards.org.au, or write to Standards Australia, GPO Box 476, Sydney, NSW 2001.

Australian Standard[®]

Pliable building membranes and underlays

Part 2: Installation

Originated in Australia as part of AS CA22—1965.
Previous edition AS/NZS 4200.2:1994.
Third edition revised and designated AS 4200.2:2017.
Reissued incorporating Amendment No. 1 (June 2018).

COPYRIGHT

© Standards Australia Limited

All rights are reserved. No part of this work may be reproduced or copied in any form or by any means, electronic or mechanical, including photocopying, without the written permission of the publisher, unless otherwise permitted under the Copyright Act 1968.

Published by SAI Global Limited under licence from Standards Australia Limited, GPO Box 476, Sydney, NSW 2001, Australia

ISBN 978 1 76035 675 0

PREFACE

This Standard was prepared by the Australian members of Joint Standards Australia/Standards New Zealand Committee BD-058, Thermal Insulation, to supersede AS/NZS 4200.2:1994, *Pliable building membranes and underlays, Part 2: Installation requirements*.

This Standard incorporates Amendment No. 1 (June 2018). The changes required by the Amendment are indicated in the text by a marginal bar and amendment number against the clause, note, table, figure or part thereof affected.

After consultation with stakeholders in both countries, Standards Australia and Standards New Zealand decided to develop this Standard as an Australian Standard rather than an Australian/New Zealand Standard.

The objective of this revision is to specify procedures for the installation of pliable building membranes in buildings that are consistent with good building practice. The requirements for installation have been compiled from a wide range of procedures used in Australia and considered as good practice in the installation of pliable building membranes.

This Standard is intended to be read in conjunction with AS/NZS 4200.1, *Pliable building membranes and underlays, Part 1: Materials*.

The term 'informative' has been used in this Standard to define the application of the appendix to which it applies. An 'informative' appendix is only for information and guidance.

This Standard incorporates a Commentary on some Clauses. The Commentary directly follows the relevant clause, is designated by 'C' preceding the clause number and is printed in italics in a panel. The Commentary is intended to help readers understand the background to the clause but does not form part of the clause.

CONTENTS

	<i>Page</i>
FOREWORD.....	4
SECTION 1 SCOPE AND GENERAL	
1.1 SCOPE.....	5
1.2 APPLICATION	5
1.3 NORMATIVE REFERENCES	5
1.4 DEFINITIONS.....	6
1.5 ELECTRICAL SAFETY	7
SECTION 2 DESIGN SPECIFICATION REQUIREMENTS	
2.1 GENERAL.....	8
2.2 VAPOUR CONTROL MEMBRANES	8
2.3 AIR CONTROL MEMBRANES (AIR BARRIERS).....	8
2.4 WATER CONTROL MEMBRANES	8
2.5 THERMAL CONTROL MEMBRANES	9
2.6 ALLOWABLE USE BASED ON DUTY CLASSIFICATIONS.....	9
SECTION 3 INSTALLATION OF PLIABLE BUILDING MEMBRANES	
3.1 SCOPE OF SECTION	10
3.2 GENERAL REQUIREMENTS.....	10
3.3 COMMON REQUIREMENTS FOR ROOFS	10
3.4 METAL SHEET ROOFING	12
3.5 TILED ROOFING	15
3.6 CEILINGS	19
3.7 COMMON REQUIREMENTS FOR WALLS	19
3.8 FRAMED WALLS	20
3.9 CAVITY MASONRY WALLS	20
3.10 SOLID MASONRY/CONCRETE WALLS, CONCRETE FLOORS AND ROOFS..	21
3.11 FRAMED FLOORS.....	23
SECTION 4 PENETRATIONS	
4.1 GENERAL.....	26
4.2 THERMAL CONTROL.....	26
4.3 VAPOUR CONTROL AND AIR CONTROL	26
4.4 WATER CONTROL.....	26
4.5 HOT FLUES.....	26
4.6 RECESSED LUMINAIRES	27
4.7 WINDOWS, ROOF WINDOWS, SKYLIGHTS AND DOORS	29
APPENDICES	
A SAFETY GUIDANCE FOR PLIABLE BUILDING MEMBRANE INSTALLATION	32
B DURABILITY	35
C PROTECTION AGAINST CONDENSATION	37
BIBLIOGRAPHY.....	40

FOREWORD

This edition of AS 4200.2 includes requirements on how to install membranes for the purpose of sarking to provide effective weather proofing. Weather proofing is achieved through the control of air, liquid water and water vapour transfer in roofs and walls. These sarking materials also commonly utilize reflective metallic coatings on one or both sides of the membrane to deliver a level of thermal control. These sarking and thermal control pliable building membranes require certain installation practices to achieve the purpose for which the product is designed and installed.

In recent years, evidence shows that there is a danger of electrocution where electrically conductive membranes are used in certain applications within the building envelope. This edition of AS 4200.2 provides advice on these safety concerns. This Standard does not purport to address all of the safety concerns associated with the use of pliable building membranes. It is the responsibility of the user of this Standard to establish appropriate work, health and safety practices and determine the applicability of regulatory requirements prior to use.

STANDARDS AUSTRALIA
Australian Standard
Pliable building membranes and underlays

Part 2: Installation

SECTION 1 SCOPE AND GENERAL

1.1 SCOPE

This Standard sets out requirements for the installation of pliable building membranes (also known as ‘sarking’ or ‘underlay’), when used either independently or as a facing to other materials, such as insulation materials, for any one or more of the following control functions:

- (a) Water control.
- (b) Thermal control.
- (c) Vapour control.
- (d) Air control.

This Standard does not cover requirements for materials used in the following applications:

- (i) Air-handling ducts and building services.
- (ii) Under concrete slabs on-ground.
- (iii) Waterproofing above flat concrete roofs.

NOTES:

- 1 The installation of foil-faced building blanket is covered in AS 3999, except for metal sheet roofing and walls, which are covered in Section 3 of this Standard.
- 2 Where regulations require special attention in bushfire prone areas, it may be necessary for a pliable building membrane to comply with AS 3959.
- 3 This Standard includes advice on work health and safety (WHS), and electrical safety (see Appendix A); however, the user of this Standard needs to refer to relevant federal, state and territory regulations and determine legal requirements as applicable.

1.2 APPLICATION

This Standard is intended to be read in conjunction with AS/NZS 4200.1.

This Standard sets out minimum requirements for the installation of pliable building membranes. It does not purport to provide for all of the requirements for any particular installation.

Care shall be taken to ensure that the requirements are applied to the intended functions of the pliable building membranes.

1.3 NORMATIVE REFERENCES

The following are the normative documents referenced in this Standard:

NOTE: Documents referenced for informative purposes are listed in the Bibliography.

AS	
2050	Installation of roof tiles
4055	Wind loads for housing

AS/NZS

3000 Electrical installations (known as the Australian/New Zealand Wiring Rules)

4200 Pliable building membranes and underlays

4200.1 Part 1: Materials

4859 Materials for the thermal insulation of buildings

4859.1 Part 1: General criteria and technical provisions

1.4 DEFINITIONS

For the purpose of this Standard, the definitions below apply.

1.4.1 Air control membrane

A membrane installed to prevent air transfer between each side of the membrane.

NOTE: Air control membranes are classified as air barriers by AS/NZS 4200.1.

1.4.2 Ceiling

Construction covering the underside of a floor or roof and providing the overhead surface of an enclosed space, often in order to conceal structural members or mechanical or electrical systems.

1.4.3 Competent person

A person, who has acquired, through training, qualification or experience or a combination of these, the knowledge and skill enabling that person to perform the required task correctly.

1.4.4 Pliable building membrane

A material that can be folded back on itself without causing structural damage to the product that affects its material properties.

1.4.5 Thermal control membrane

A membrane with a surface emissivity and/or material R-value intended to reduce heat transfer.

NOTE: Thermal control membranes are commonly referred to as 'reflective insulation' or 'reflective foil laminates'.

1.4.6 Vapour control membrane

A pliable building membrane designed to either allow or restrict the transfer of water vapour across the membrane, as classified in Table 1 of AS/NZS 4200.1.

NOTE: Previous editions of this Standard referred to vapour barrier low/medium/high. All membranes are now classified in accordance with their vapour permeance and all are considered vapour control membranes.

1.4.7 Water control membrane

A membrane classified as a water barrier according to AS/NZS 4200.1, intended to collect and discharge any water that may penetrate a building envelope or cladding, excluding damp-proofing and flashing materials.

NOTE: Water control membranes are commonly referred to as 'sarking'.

1.4.8 Unprotected circuit

An electrical circuit that has not been fitted with an approved safety switch.

NOTE: The following are examples of unprotected circuits:

- (a) Air-conditioning.
- (b) Consumer mains.
- (c) Hot water systems.
- (d) Solar systems.
- (e) Stoves.
- (f) Sub-mains in particular circumstances.

1.5 ELECTRICAL SAFETY

CAUTION: ELECTRICALLY CONDUCTIVE MEMBRANES CAN CREATE A HAZARD WHEN CONTACTING LIVE CONDUCTORS.

NOTE: For guidance on electrical safety in pliable building membrane installation, see Appendix A.

SECTION 2 DESIGN SPECIFICATION REQUIREMENTS

2.1 GENERAL

This Section sets out requirements for the design of pliable building membranes, and includes the properties and functions of pliable building membranes that need to be considered in the design specification.

The pliable building membrane shall be installed to satisfy the design specification, intended purpose, performance properties and function of the membrane.

The design shall specify the purpose and required properties of the membrane, selected in accordance with AS/NZS 4200.1, and identify—

- (a) where the membrane shall be installed within the building system, including adjacent air gaps for thermal performance;
- (b) the material properties of the membrane with information to enable the selection of the membrane; and
- (c) fixing and sealing requirements for thermal performance, weatherproofing and water vapour management strategies.

NOTE: Guidance on durability is provided in Appendix B.

2.2 VAPOUR CONTROL MEMBRANES

Where a pliable building membrane is installed as a vapour barrier, Class 1 or Class 2, it shall be continuously sealed at all discontinuities, end laps, joints and penetrations, by one of the following:

- (a) Heat and moisture resistant adhesive tape.
- (b) Mechanical fixing with adhesive sealant.
- (c) Adhesive bond.

NOTE: Bulk insulation or additional ventilation may also assist in reducing the condensation risk when used in conjunction with vapour control membranes.

C2.2 Vapour control membrane Class 1 is equivalent to a vapour barrier high, and Class 2 is equivalent to vapour barrier medium, as per AS/NZS 4200.1:1994.

2.3 AIR CONTROL MEMBRANES (AIR BARRIERS)

Where a pliable building membrane is to be installed as an air barrier, it shall be classified as an air barrier, in accordance with AS/NZS 4200.1. Where installed as an air barrier, the membrane shall be taped or sealed at overlaps, end laps, discontinuities and penetrations. This shall be achieved using the sealing requirement specified in Clause 2.2.

2.4 WATER CONTROL MEMBRANES

Where a pliable building membrane is to be installed as a water control membrane (sarking) in a building, it shall be installed at a slope of no less than 2° to facilitate drainage.

A pliable building membrane installed in a roof as a sarking membrane shall be classified as a water barrier in accordance with AS/NZS 4200.1.

2.5 THERMAL CONTROL MEMBRANES

Where a pliable building membrane is to be installed as a thermal control membrane, it shall be installed with an air gap either—

- (a) as calculated in accordance with AS/NZS 4859.1; or
- (b) not less than 20 mm.

Calculation of total R-value shall be in accordance with AS/NZS 4859.1.

NOTE: Where thermal control membranes are designed for a metal roof, the following should be considered:

- (a) Where thermal control membranes are installed over the battens, condensation may occur at the batten in some localities. This would be reduced if the sarking were installed under the batten. Where installed over the battens, additional condensation measures may be required. For guidance on protection against condensation, see Appendix C.
- (b) Where installed over the battens, elevated daytime temperatures of roofs may lead to product deterioration in some localities. Information on appropriate membrane working temperatures should be sought.
- (c) The total R-value of the thermal control membrane is dependent on the heat flow direction and air gap provided. Refer to the product label and specifications for correct product orientation.

2.6 ALLOWABLE USE BASED ON DUTY CLASSIFICATIONS

The allowable use shall be determined in accordance with the duty classification specified in AS/NZS 4200.1, and the spans outlined in Table 2.6. Where the spans exceed those specified in Table 2.6, the membrane shall be supported from below.

NOTE: The support may be safety mesh or rigid sheeting.

TABLE 2.6
DUTY CLASSIFICATION AND ALLOWABLE USAGE
IN AUSTRALIA

Application	Supported	Unsupported
Walls and gables	Light wall	Light wall
Tiled roofing:		
≤600 mm spans (wind class ≤ N2)	Medium duty	Medium duty
≤600 mm spans (wind class > N2)	Medium duty	Heavy duty
>600 mm ≤900 mm spans	Medium duty	Extra heavy duty
>900 mm spans	Medium duty	*
Metal sheet roofing, ceilings and floors:		
≤900 mm spans	Light duty	Light duty
>900 to ≤1200 mm spans	Light duty	Medium duty
>1200 mm spans	Medium duty	*

* Outside the scope of this Standard.

NOTE: Higher duty classified products and/or reduced fastener spacings should be considered where membranes are likely to be exposed to adverse weather conditions during construction, prior to cladding or in applications requiring higher differential air pressures.

C2.6 Allowable use duty classifications are based on the wind conditions experienced by the membrane in its fully constructed configuration.

SECTION 3 INSTALLATION OF PLIABLE BUILDING MEMBRANES

3.1 SCOPE OF SECTION

This Section sets out requirements for the installation of pliable building membranes within the structure depending on the location and functions specified.

3.2 GENERAL REQUIREMENTS

When installing pliable building membranes, the following requirements apply:

- (a) Damage or tears to the membrane shall be repaired to restore the integrity and maintain the purpose of the membrane.
- (b) The membrane shall be cut to provide a neat fit around obstacles and penetrations (see Section 4).
- (c) Exposure of pliable building membranes to intense heat, sparks, flames or abrasive tools shall be avoided.
- (d) Where a pliable building membrane is installed as a vapour control membrane, Class 1 or Class 2, or as an air barrier, it shall be continuously sealed at all discontinuities, end laps, joints and penetrations by—
 - (i) a pressure sensitive, heat and moisture resistant tape;
 - (ii) adhesive of equal or greater vapour resistance than the vapour control membrane;
 - (iii) heat and moisture resistant adhesive tape;
 - (iv) mechanical fixing with adhesive sealant; or
 - (v) adhesive bond.

NOTES:

- 1 Installation of electrically conductive membranes increases the risk of electrocution, in particular for installations in roofs, ceilings, walls and floors where electrical wiring or equipment is present.
- 2 Working in ceiling spaces presents a potential safety hazard.
- 3 Guidance on installation safety considerations is provided in Appendix A.

3.3 COMMON REQUIREMENTS FOR ROOFS

3.3.1 General

This Clause (3.3) specifies requirements for the installation of pliable building membranes in roofs.

NOTE: Additional requirements are given in Clauses 3.4 and 3.5 for metal sheet roofs and tiled roofs respectively.

The following requirements apply to the installation of pliable building membranes in roofs:

- (a) The pliable building membrane shall be selected and installed to fulfil the function specified in the design.
- (b) All joints shall be—
 - (i) overlapped not less than 150 mm; or
 - (ii) overlapped not less than 50 mm and taped on the exterior face (see Note 1).

- (c) All end joints shall be positioned over supporting members.
- (d) The pliable building membrane shall be supported by either—
 - (i) draping over the roof battens, trusses or rafters, with a sag at a slope of not less than 2° to facilitate drainage; or
 - (ii) supporting on safety mesh or other continuous support where available.
- (e) Installation across the roof trusses or rafters shall be by unrolling parallel to the fascia, where positioned below the roof battens (see Note 2).
- (f) The pliable building membrane shall continue over the ridge with an overlap of not less than 150 mm. Where specifically designed ridge ventilation is installed, the membrane shall be terminated at the ventilation.
- (g) The pliable building membrane shall be cut around obstacles, and all openings shall be sealed (see Section 4). Special care shall be taken to avoid tearing or puncturing the pliable building membrane during its installation, such as by contact with back edges of gutters.
- (h) At valleys, the pliable building membrane shall be carried beyond the inside vertical face of the valley batten, turned down into the edge of the valley tray and held in place between the metal roof sheet and valley batten by fixing the valley batten parallel to the valley gutter (as shown in Figure 3.3.1). The membrane shall overlap the valley edge by not less than 25 mm.
- (i) At fascias and barges, the pliable building membrane shall extend beyond the front edge of the fascia or barge and protrude not more than 25 mm beyond the fascia or barge [as shown in Figure 3.5.1(C)] (see Note 3).
- (j) Where acting as a water control membrane, the pliable building membrane shall be installed at a slope of no less than 2 degrees to facilitate drainage (see Note 4).

NOTES:

- 1 The tape used should be membrane compatible and appropriate for the application environment.
- 2 Fasteners may be needed to maintain uniform overlaps between successive runs prior to fixing the roof battens.
- 3 Where gutter overflow measures require a controlled gap between gutter and fascia, care should be taken to ensure the membrane or insulation blanket does not impede normal gutter flow or overflow paths.
- 4 Where the product data sheets indicate pliable building membranes are susceptible to shrinkage under elevated temperatures, they should be installed under the battens to separate the membrane from the cladding.

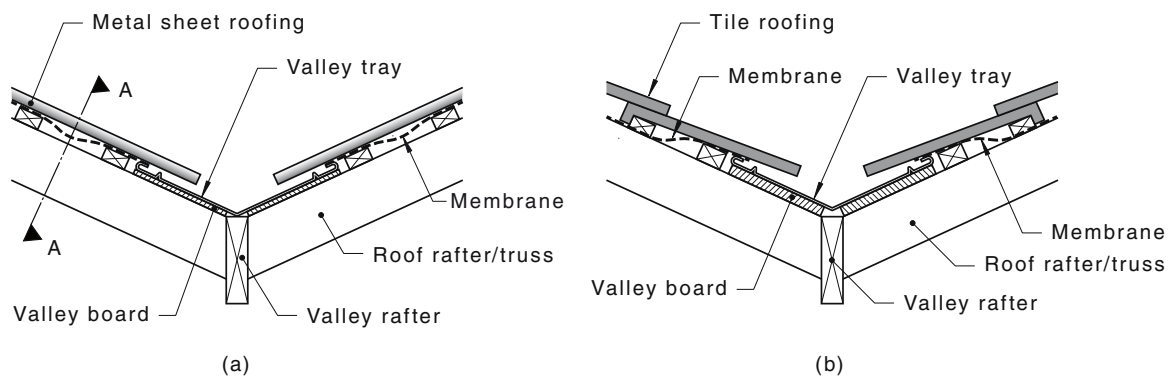

FIGURE 3.3.1 TREATMENT OF ROOFS AT VALLEYS WITH SARKING OVER AND UNDER BATTENS

3.3.2 Thermal control membranes

Where a pliable membrane is to function as a thermal control membrane, the membrane shall be installed in accordance with Clause 2.5.

3.3.3 Water control membranes (sarking)

Where a pliable building membrane is intended to function as a water control membrane, the upper sheets shall overlap the lower sheets by not less than 150 mm, or 50 mm taped on the exterior face to ensure water is shed to the outside face of the membrane. All penetrations shall be sealed as outlined in Section 4 and the membrane shall be installed to facilitate drainage to the building flashing.

NOTES:

- 1 For treatment of the fascia for high pitched roofs, see Figure 3.5.1(C).
- 2 For treatment of the fascia for low pitched roofs, see Figure 3.5.1(D).

3.3.4 Membrane support systems

Where the pliable building membrane is required by Clause 2.6 to be supported from below, the support system shall be for the intended use.

3.4 METAL SHEET ROOFING

3.4.1 General

The installation of a pliable building membrane beneath metal sheet roofing shall be as follows:

- A1
- (a) Where positioned above the roof purlins/battens, the following applies:
 - (i) The pliable building membrane shall be—
 - (A) installed by unrolling from ridge to eave [see Figure 3.4.1(a)]; or
 - (B) installed by unrolling parallel to the fascia, provided all side joints occur over a roof batten or purlin, [see Figure 3.4.1(b)] where the membrane is unsupported.
 - (ii) All joints shall be installed in accordance with Clause 3.3.1(b).
 - (b) Where intended to be positioned below the roof purlins/battens, the pliable building membrane shall be installed across the roof trusses or rafters by unrolling parallel to the fascia [see Figures 3.4.1(c)] (see Note 3).
 - (c) Where faced to a bulk insulation blanket, the pliable building membrane shall be terminated at the external edge of the fascia or, in the absence of a fascia, at the last batten.
 - (d) For rafter construction with horizontal lay, jointing of lengths of pliable building membranes shall be achieved by overlapping the ends of the pliable building membrane and fastening the pliable building membrane to the rafters.

NOTES:

- 1 Placing a reflective membrane under a metal roof and over rather than under the battens may increase the risk of condensation forming on the underside of the membrane. For guidance on protection against condensation, see Appendix C.
- 2 On low pitch metal roofs, draping of the membrane between purlins can result in ponding which should be avoided. In such cases it is preferable for the membrane to be fully supported to give a clear drainage path. If not practical on low pitch roofs then the overlap should be sealed to prevent water ingress to the ceiling space below.
- 3 Fasteners may be needed to maintain uniform overlaps between successive runs prior to fixing the roof battens.

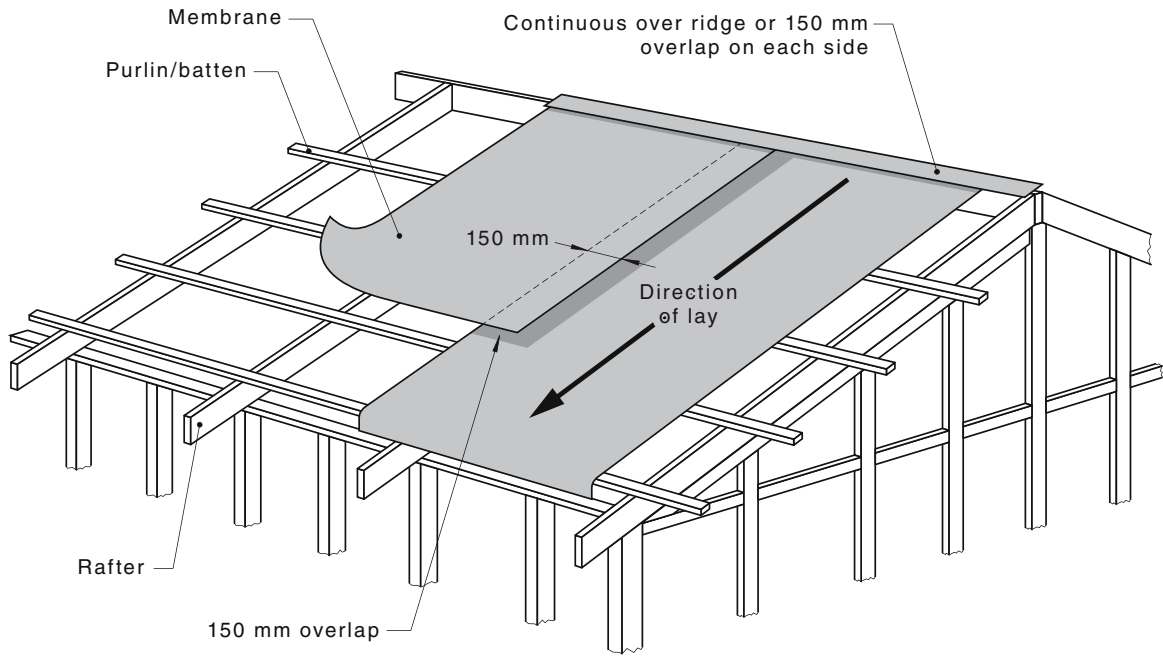

(a) Over battens—Option A

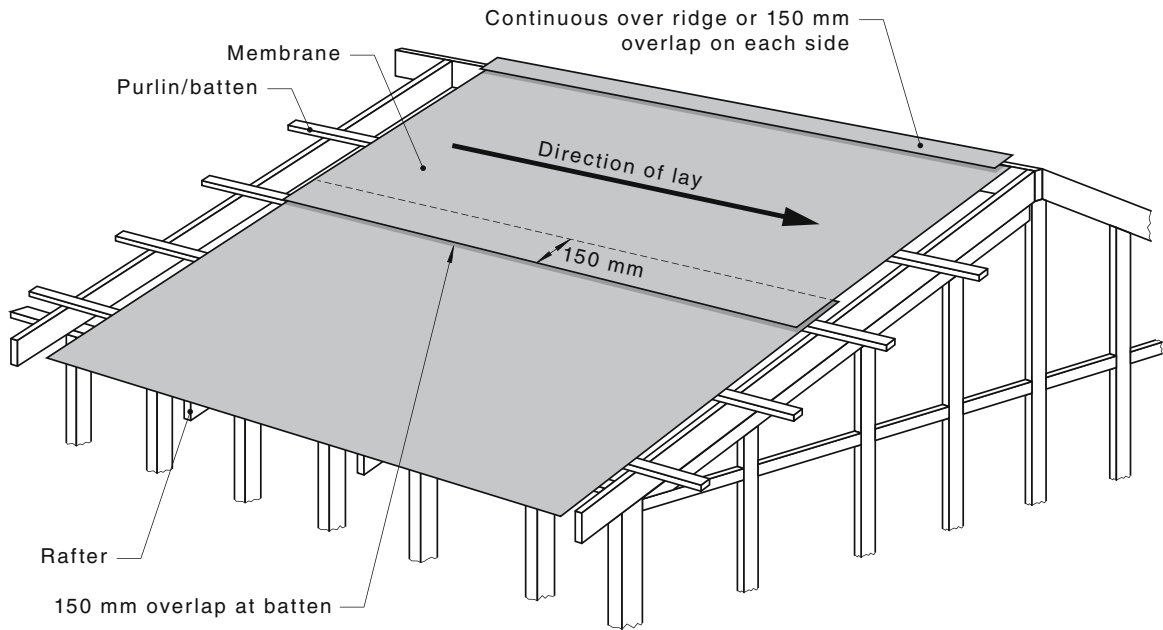

(b) Over battens—Option B

FIGURE 3.4.1 (in part) INSTALLATION OF MEMBRANES UNDER METAL ROOFS

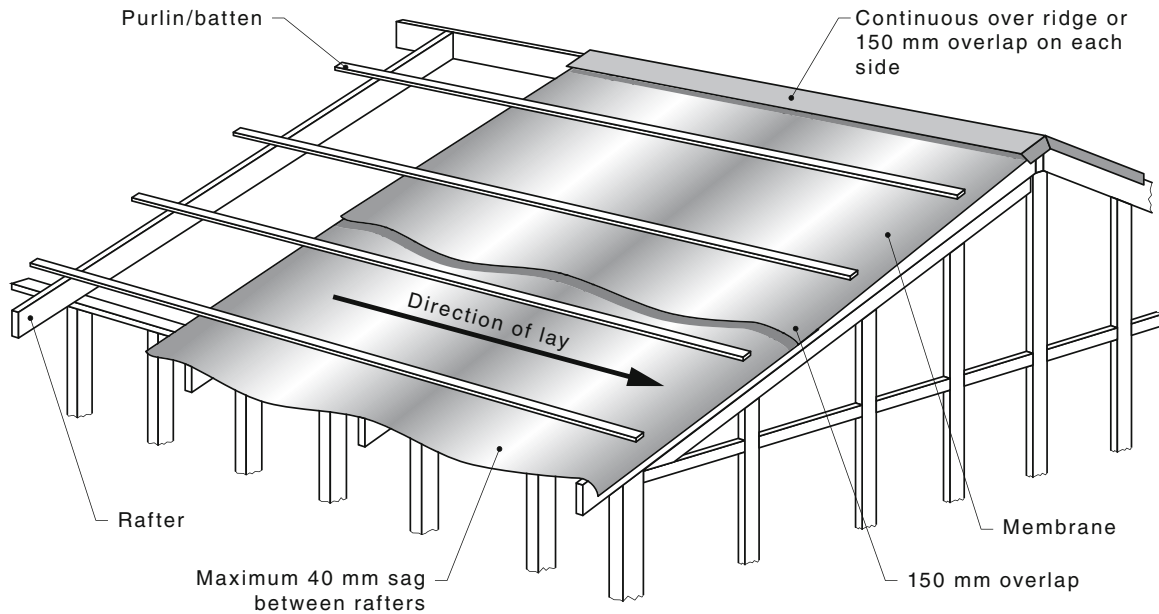

(c) Under battens

FIGURE 3.4.1 (in part) INSTALLATION OF MEMBRANES UNDER METAL ROOFS

3.4.2 Thermal control membranes under metal roofs

Where a pliable building membrane is specified to function as a thermal control membrane, the following additional requirements shall be met:

- (a) The designed air gap(s) shall be maintained.
- (b) A thermal control membrane with upward facing infrared (IR) reflective surface shall be installed with the air gap either—
 - (i) as calculated in accordance with AS/NZS 4859.1; or
 - (ii) not less than 20 mm.

Where the membrane is installed under the roof battens, a maximum sag of 40 mm shall be provided.

NOTE: A typical example is shown in Figure 3.4.2.

Where pliable building membranes are installed over the battens, a minimum 20 mm air gap between the underside of the sheet roofing and the pliable building membrane shall be provided.

NOTES:

- 1 When installed over the battens, elevated daytime temperatures of dark absorbent roofs may lead to product deterioration in some localities. Information on appropriate membrane working temperatures should be sought.
- 2 The total and system R-value of reflective insulation is dependent on heat flow direction and the air gap provided. Refer to Table 3 of AS/NZS 4200.1 for product label for membrane emittance category, and design specifications for correct IR surface emittance orientation.

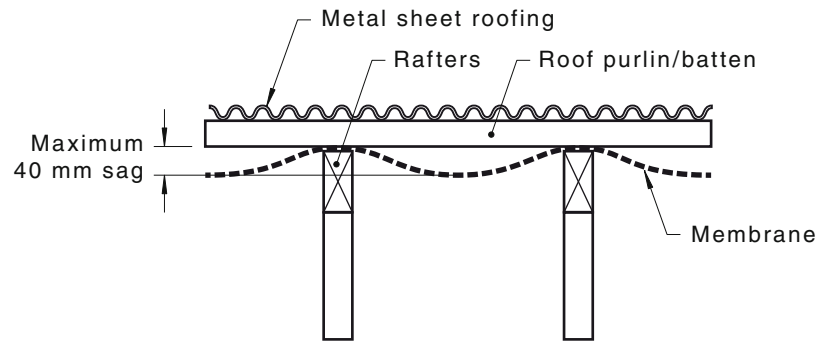

FIGURE 3.4.2 INSTALLATION OF MEMBRANE AS REFLECTIVE INSULATION—
UNDER BATTENS

3.4.3 Vapour control and air control

Where a pliable building membrane is installed as a vapour barrier or as an air control membrane, either independently or faced to a bulk insulation blanket, the design measures stipulated in Clauses 2.2, 2.3 and 3.2(d) shall be met.

NOTE: Installation of foil faced bulk insulation is also covered in AS 3999.

3.5 TILED ROOFING

3.5.1 General

A pliable building membrane beneath tiled roofing shall be—

- (a) positioned below the roof battens; and
- (b) installed across the roof trusses or rafters by unrolling parallel to the fascia.

NOTES:

- 1 For a typical installation under a tiled roof, see Figure 3.5.1(A).
- 2 Fasteners may be needed to maintain uniform overlaps between successive runs prior to fixing the roof battens.

The laying of pliable building membranes beneath tiled roofing shall comply with the following:

- (i) The pliable building membrane shall be draped across the rafters or trusses, prior to battening, with a sag not greater than 40 mm or not greater than the supporting battens [see Figure 3.5.1(B)].
- (ii) Successive courses of the pliable building membrane shall overlap the adjoining course to ensure continuity of water flow and air pressure. This shall be achieved with a side lap of not less than 150 mm, or 50 mm taped on the exterior face; when the pliable building membrane is secured to each rafter [refer to Figure 3.5.1(A)].
- (iii) In the case of rafter construction, jointing of lengths of the pliable building membrane shall be achieved by overlapping the ends of the pliable building membrane one rafter space and fastening the pliable building membrane to the rafters.
- (iv) The pliable building membrane shall be fixed so that the membrane drains into the gutter, as shown in Figures 3.5.1(C) and 3.5.1(D). An anti-ponding device/board shall be provided in accordance with AS 2050.

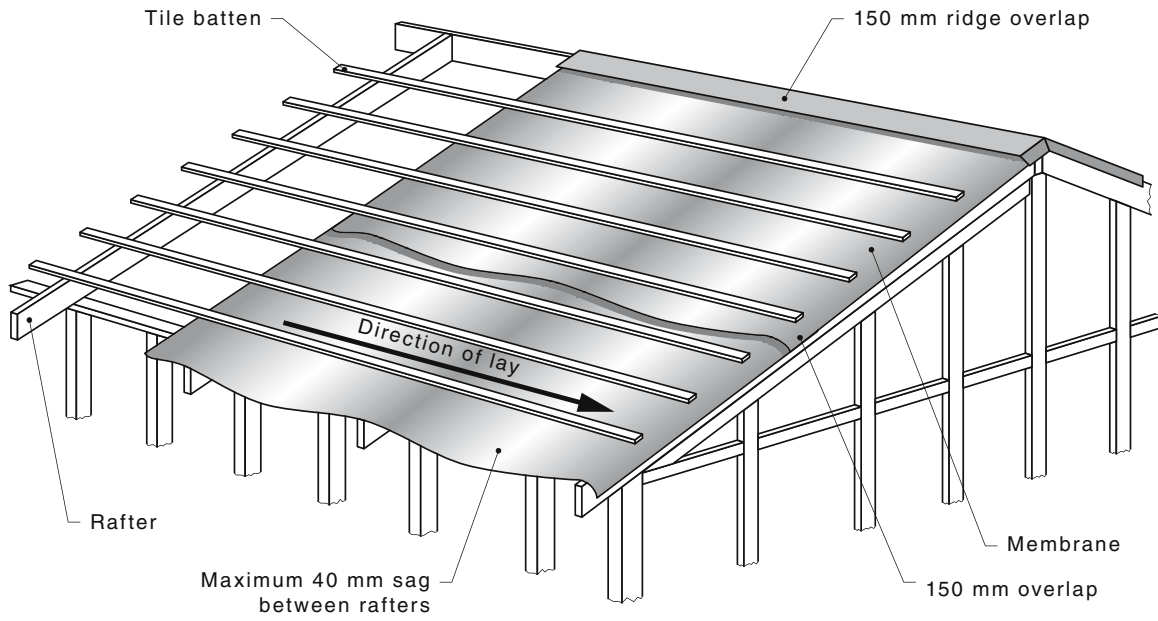

FIGURE 3.5.1(A) INSTALLATION OF MEMBRANE UNDER TILED ROOF

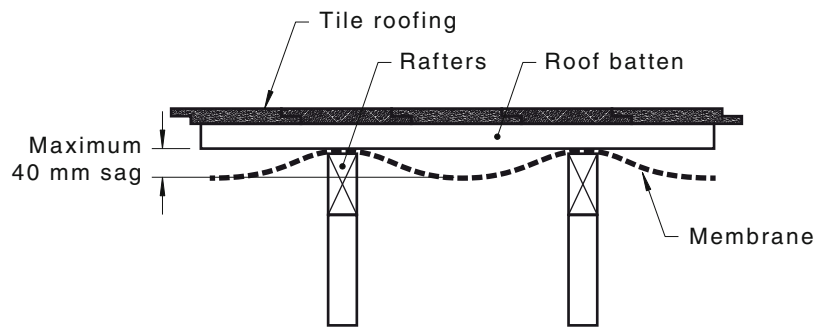

FIGURE 3.5.1(B) INSTALLATION OF MEMBRANE UNDER BATTENS WITH SAG

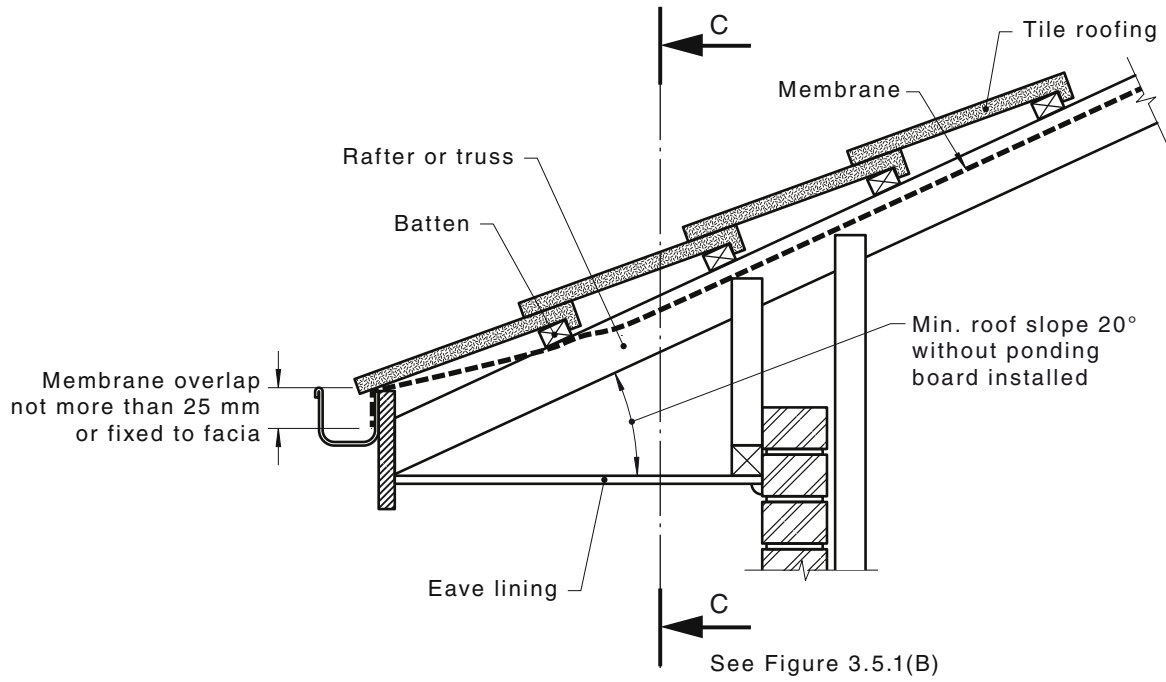

FIGURE 3.5.1(C) HIGH PITCHED TILED ROOF (NO ANTI-PONDING BOARD)—MEMBRANE INSTALLED UNDER BATTENS

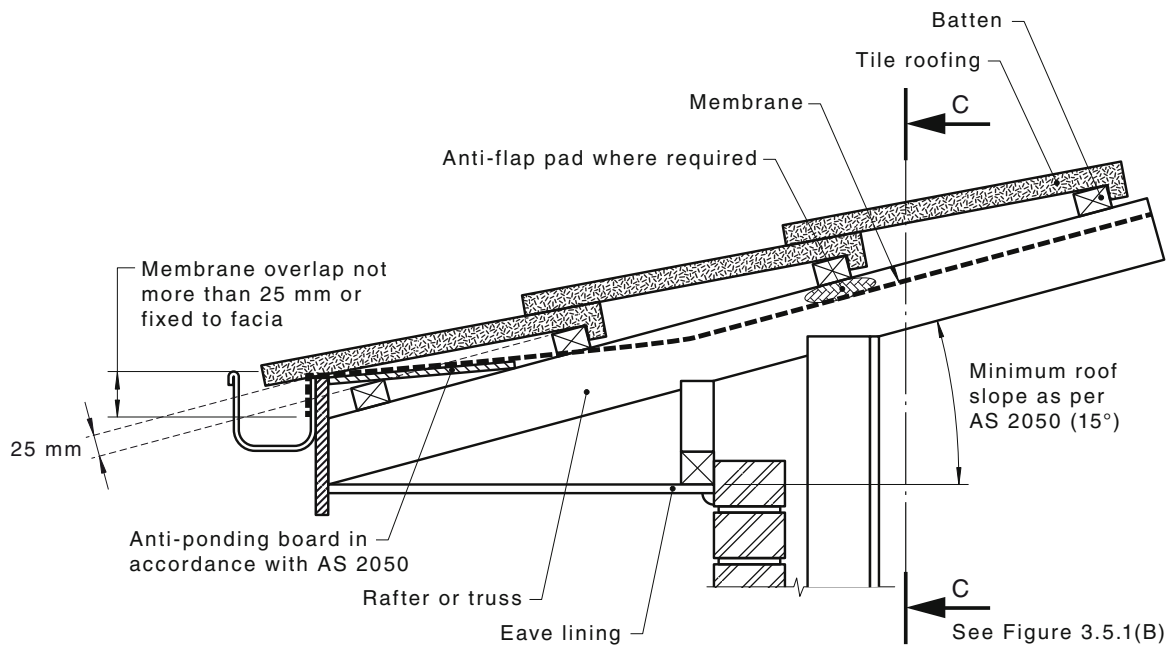

FIGURE 3.5.1(D) LOW PITCHED TILED ROOF (WITH ANTI-PONDING BOARD)—MEMBRANE INSTALLED UNDER BATTENS

3.5.2 Thermal control membrane under tiled roofs

Where a pliable membrane is intended to function as a thermal control membrane, the membrane shall be installed with the calculated air gap to achieve the required R-value between each side of the membrane and a building lining or cladding. Thermal control membranes shall be installed with the air gap either—

- (a) as calculated in accordance with AS/NZS 4859.1; or
- (b) not less than 20 mm.

Where the membrane is installed under the roof battens, it shall be installed with a sag of no more than 40 mm [see Figure 3.5.1(B)].

NOTE: The total and system R-value of reflective insulation is dependent on heat flow direction and degree of ventilation. Refer to product label and specifications.

3.5.3 Treatment at eaves

Where anti-ponding boards are installed, the membrane shall be installed over the anti-ponding board into the gutter, as shown in Figure 3.5.1(D).

NOTE: Where sarking membranes are installed over battens (between the battens and roof cladding) an anti-ponding board may be installed.

3.5.4 Treatment at valleys

The pliable building membrane shall be carried beyond the inside vertical face of the valley raking batten and shall be turned down into the edge of the valley gutter drip so that it does not impede water running down the valley gutter (refer to Figure 3.3.1).

3.5.5 Treatment at ridges

In all cases, the pliable building membrane, where installed, shall continue over the ridge (refer to Figure 3.5.5).

Where roof ventilation is required, penetration in the sarking shall be provided and treated in accordance with Section 4.

Where design gust wind speeds are above N3 or C1 in accordance with AS 4055, sarking with anti-flap pads shall be used irrespective of roof pitch [refer to Figure 3.5.1(D)].

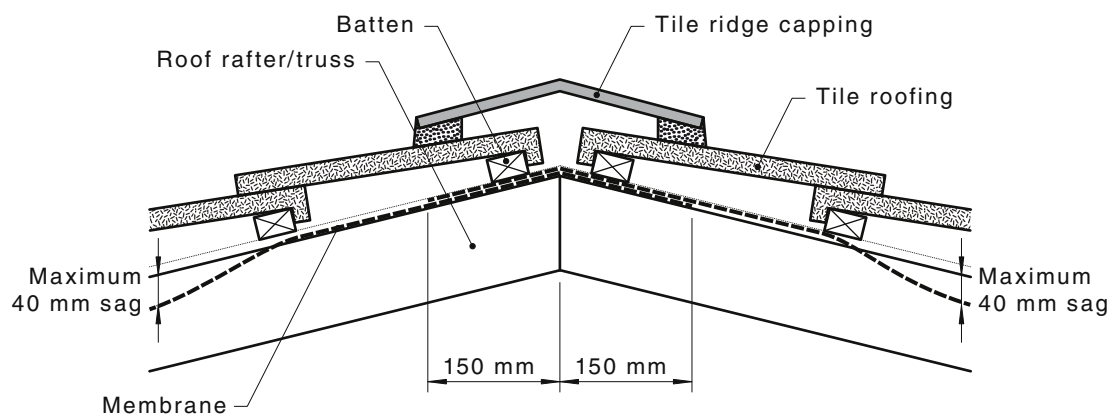

FIGURE 3.5.5 TREATMENT OF TILED ROOF AT RIDGES

3.6 CEILINGS

3.6.1 General

This Clause (3.6) applies to membranes that are located under or on top of the bottom chord of roof trusses or ceiling joists in attic roofs with flat ceilings or below roof rafters but above the ceiling lining.

NOTE: When installing membranes in a ceiling space, consideration of electrical safety should be made in accordance with Clause 1.5.

3.6.2 Flat and raked ceilings

3.6.2.1 Direction of lay

Where pliable building membranes are installed at the ceiling level, they shall be supported by the ceiling structural members, such as the ceiling joists or battens. The membrane shall be installed either parallel to or perpendicular to the structural members. The ends and sides of the membranes shall not be in contact with the ceiling.

NOTES:

- 1 The membrane should be secured in its designed position to the supporting structure, with the ends and sides of the membrane in their designed positions.
- 2 For guidance on electrically conductive membranes, see Appendix A.

3.6.2.2 Thermal control membranes

Where a pliable building membrane is installed as a thermal control membrane in ceilings, it shall have an air gap adjacent to its IR reflective (emittance of ≤ 0.05) face(s) in order to achieve the required thermal performance.

NOTE: For a typical configuration, see Figure 3.6.2.2.

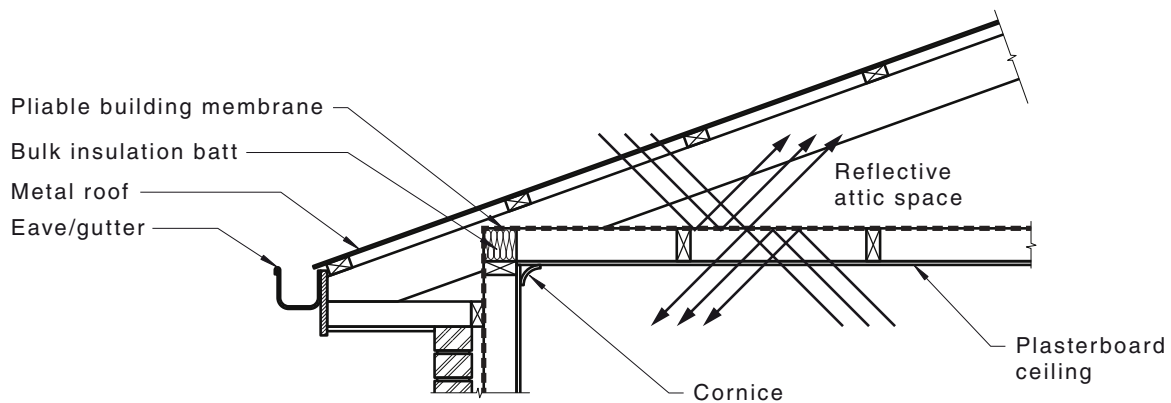

FIGURE 3.6.2.2 TYPICAL CONFIGURATION OF THERMAL CONTROL MEMBRANES

3.6.2.3 Air and vapour control membranes

Membranes installed at ceiling level as air barriers or vapour barriers shall be sealed with tape or sealed at joints and penetrations.

3.7 COMMON REQUIREMENTS FOR WALLS

3.7.1 General

When installing pliable building membranes in walls, the following requirements apply.

Installation of pliable building membranes in walls shall be as follows:

- (a) All joints shall be—
 - (i) lapped not less than 150 mm;
 - (ii) lapped not less than 50 mm jointed and taped; or
 - (iii) butt-jointed and taped where the combined uncompressed nominal material thickness is greater than 5 mm and overlapping will compromise cladding installation.
- (b) All end laps shall be fixed at a stud to form a continuous membrane.

3.7.2 Thermal control membrane

Where a pliable building membrane is installed for thermal control, the membrane shall be installed with the air gap either—

- (a) as calculated in accordance with AS/NZS 4859.1; or
- (b) not less than 20 mm.

NOTE: When the stud cavity is filled with bulk insulation, the inward facing air gap R-value of the pliable building membrane no longer contributes to the total wall system R-value.

3.7.3 Water control membrane

Where a pliable building membrane is installed as a water control membrane, the upper sheets shall lap over the lower sheets, to ensure water is shed to the outside face of the membrane.

3.8 FRAMED WALLS

3.8.1 Timber frame walls

Where a pliable building membrane is installed on a timber frame it shall be fixed to the timber stud using mechanical fixings at 150 mm centres, prior to cladding.

3.8.2 Metal frame walls

Where a pliable building membrane is installed onto a steel frame it shall be fixed to the steel studs using—

- (a) adhesive when cladding is directly fixed to the stud work; or
- (b) mechanical fixings with a broad headed washer at 300 mm centres for cavity walls, prior to cladding.

NOTE: For cavity applications, fixings should be in accordance to the manufacturer's recommendations.

3.9 CAVITY MASONRY WALLS

The installation of pliable building membranes in cavity masonry walls shall be as follows:

- (a) One leaf of masonry shall be built to a height at least adequate to install one roll width of membrane, when rolled out horizontally.
- (b) Where reflective air gaps are required for thermal insulation, spacers shall be positioned against the masonry to ensure that the calculated air gap is achieved and maintained in accordance with Clause 3.7.2.
- (c) The membrane shall be neatly cut to allow the wall ties to penetrate through the membrane and the membrane shall be supported by the wall ties. The membrane shall be supported on the brick wall ties and positioned with spacers of thickness to maintain the calculated air gap.

- (d) When the pliable building membrane is in position, all joints shall be taped if required by Clause 3.7.1.
- (e) When the membrane is positioned and taped if required, the final leaf of brickwork shall be constructed.
- (f) Mortar shall not be allowed to contaminate the reflective surface. This shall be achieved by ensuring droppings do not occur in the cavity, use of a cavity board, washing the cavity while mortar is still plastic, or other means that prevent the reflective surface from being contaminated.

NOTES:

- 1 For a typical configuration of a pliable building membrane in a masonry cavity walls, see Figure 3.9.
- 2 For guidance on protection against condensation, see Appendix C.

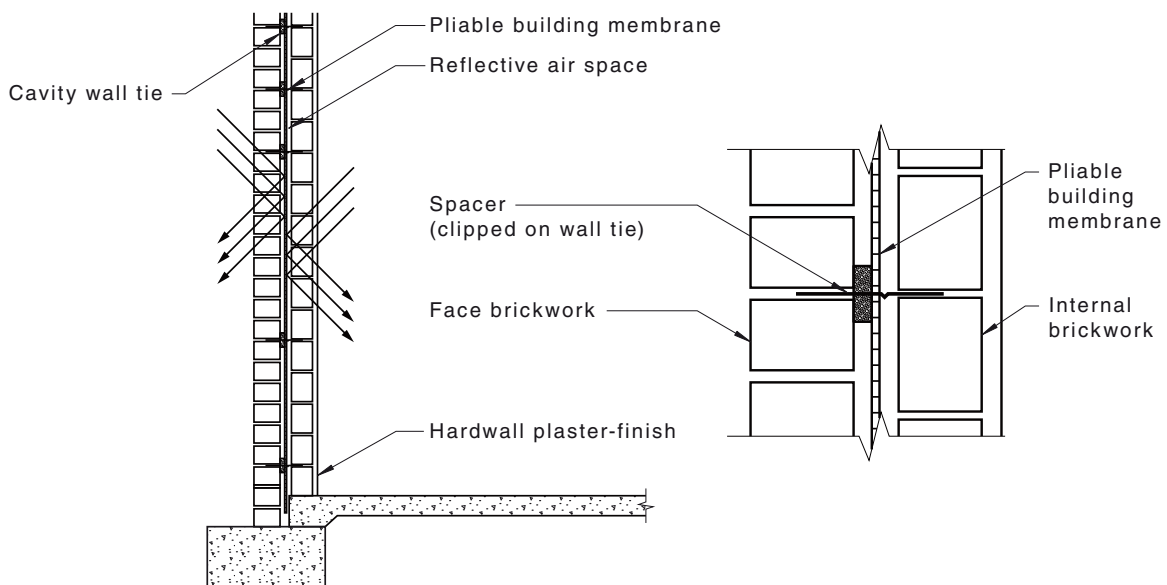

FIGURE 3.9 TYPICAL CONFIGURATION OF PLIABLE BUILDING MEMBRANE IN MASONRY CAVITY WALL

3.10 SOLID MASONRY/CONCRETE WALLS, CONCRETE FLOORS AND ROOFS

The installation of pliable building membranes in solid masonry or concrete walls shall be as follows:

- (a) Where reflective air gaps are required for thermal insulation, spacers shall be positioned against the masonry or concrete to ensure that the calculated air gap is achieved and maintained, in accordance with Clause 3.7.2.
- (b) The membrane shall be neatly cut to allow any lining clips or ties to penetrate through the membrane.
- (c) Where the membrane is installed for thermal purposes, it shall be secured in position by means of temporary or permanent fixings such that the air gap, as specified in Clause 3.7.2, is maintained through the framing, battens, furring channels, spacers, or the like, in such a manner as to not compromise any fixings or mountings of any internal wall linings.
- (d) When the pliable building membrane is in position, all joints shall be taped if required by Clause 3.7.1.

- (e) If an interior lining is designed, when the membrane is positioned, and taped if required, the final interior lining shall be installed.

NOTES:

- 1 For an example of a pliable building membrane installed in a solid masonry or concrete wall, see Figure 3.10(A).
- 2 For an example of a pliable building membrane installed under a suspended solid masonry or concrete slab, see Figure 3.10(B).

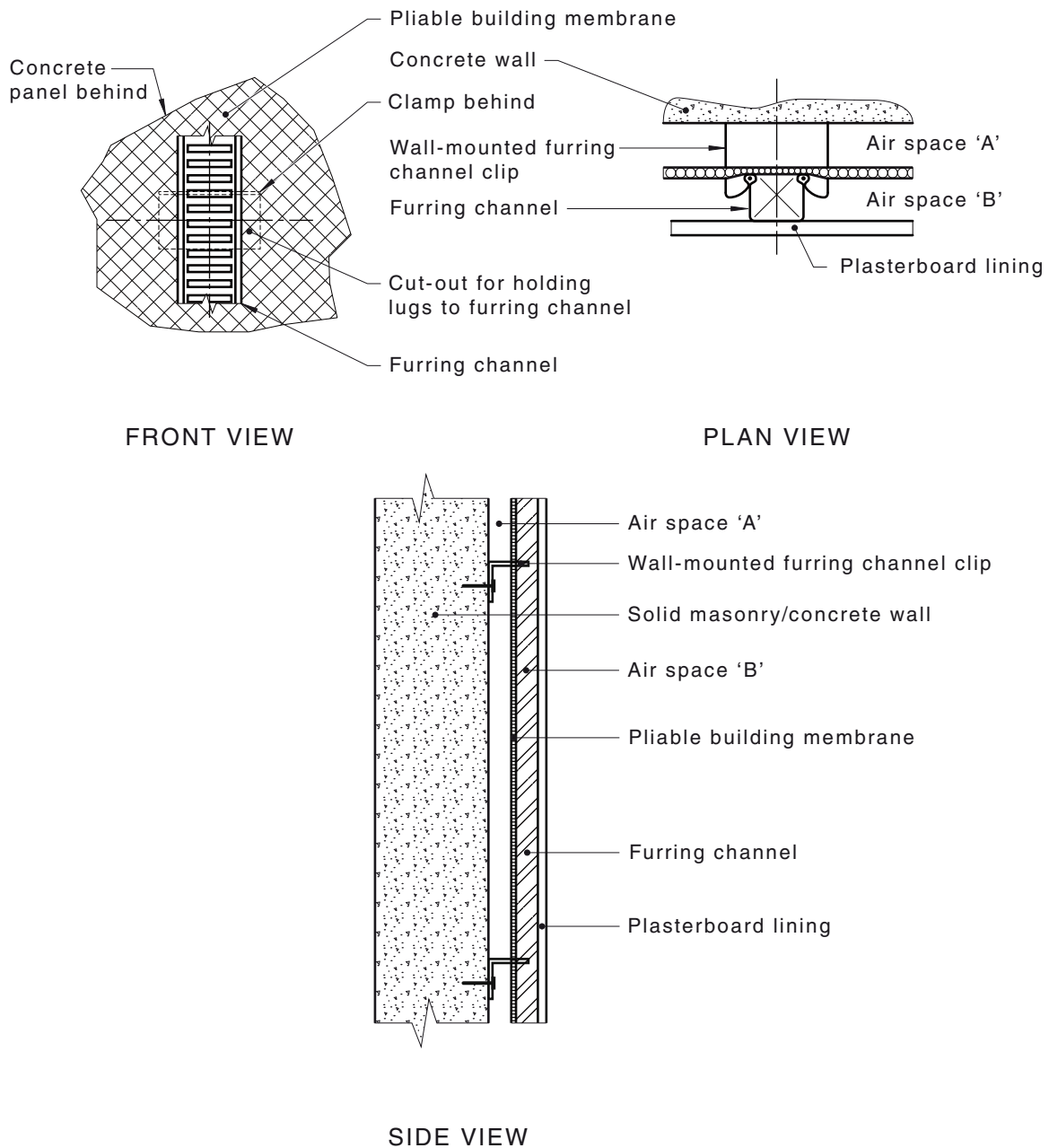

FIGURE 3.10(A) EXAMPLE OF PLIABLE BUILDING MEMBRANE IN A SOLID MASONRY/CONCRETE WALL

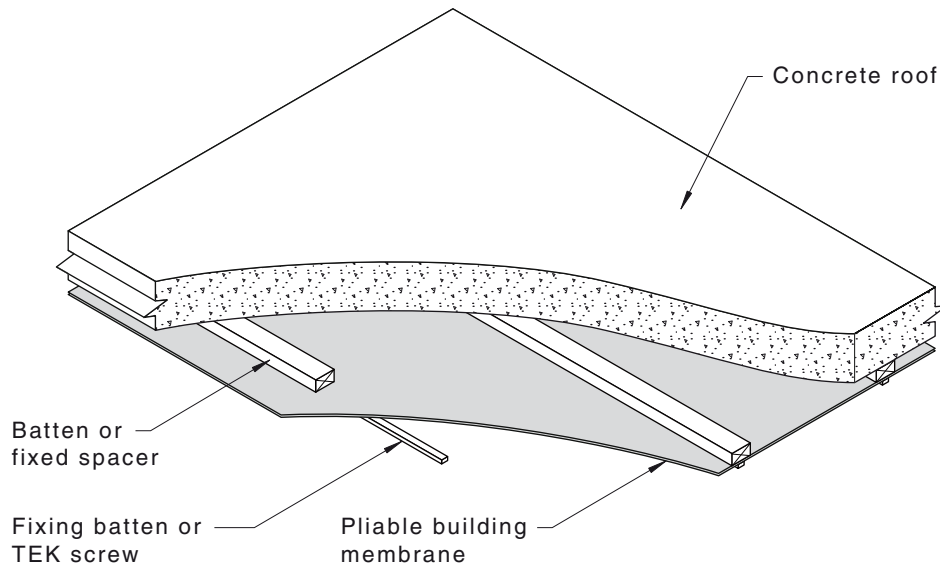

FIGURE 3.10(B) EXAMPLE OF PLIABLE BUILDING MEMBRANE UNDER A SUSPENDED CONCRETE SLAB

3.11 FRAMED FLOORS

3.11.1 General

Pliable building membrane shall be installed over or under the joists using fixings that are appropriate to the type of floor constructions and appropriate for the membrane used.

NOTES:

- 1 For examples of installation of pliable building membranes over or under floor joists, see Figure 3.11.1.
- 2 For allowable fixings near electrical cables, see Appendix A.

3.11.2 Position of lay

If installed over the joists, the pliable building membrane shall not compromise the fixing of the chosen flooring. The membrane shall be installed with—

- (a) the air gap as calculated in accordance with AS/NZS 4859.1; or
- (b) an air gap of not less than 20 mm; or
- (c) a sag more than 40 mm between joists.

For this method the pliable building membrane shall be joined and taped.

If installed between the joists the pliable building membrane shall be laid parallel to floor joists, ensuring it is set in between the joists to the depth in-line with the bottom of the floor joist. Pliable building membranes installed between the joists shall be fixed at a maximum of 150 mm centres.

3.11.3 Thermal control membrane

Where a pliable building membrane is installed as a thermal control membrane under floors (other than ground floors), it shall be installed in accordance with Clause 2.5.

3.11.4 Vapour control membranes and air control membranes

Where a pliable building membrane is installed as a vapour barrier or as an air barrier, it shall be sealed in accordance with Clause 3.2.

NOTE: Where there is a risk of water accumulation, perforations should be made in the membrane to allow for sufficient drainage. If the membrane is perforated, it will no longer function as an air barrier or vapour barrier.

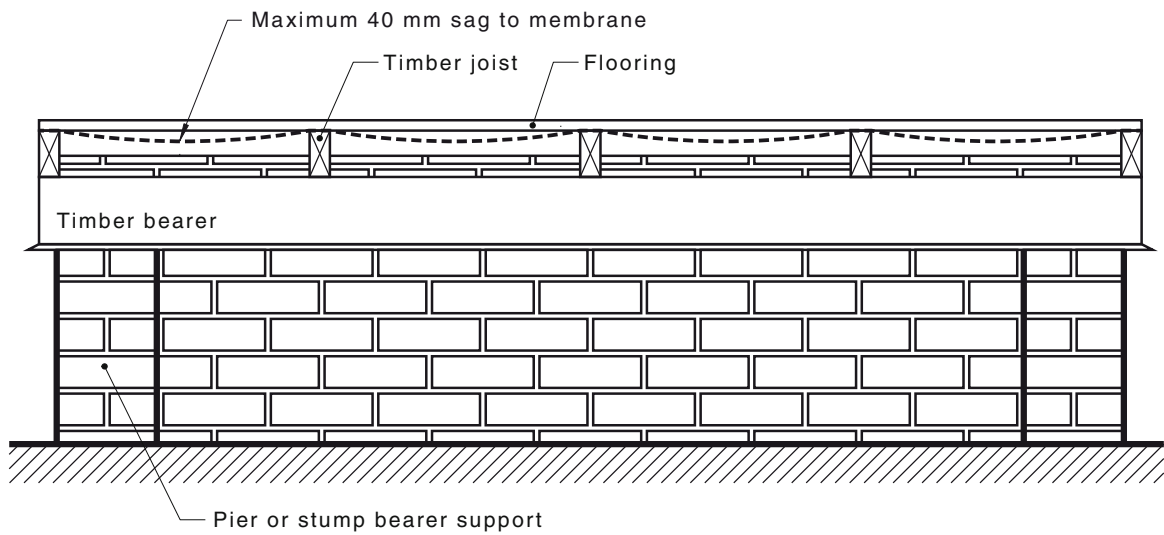

(a) Pliable building membrane installed under timber-framed floor (installed over joists)

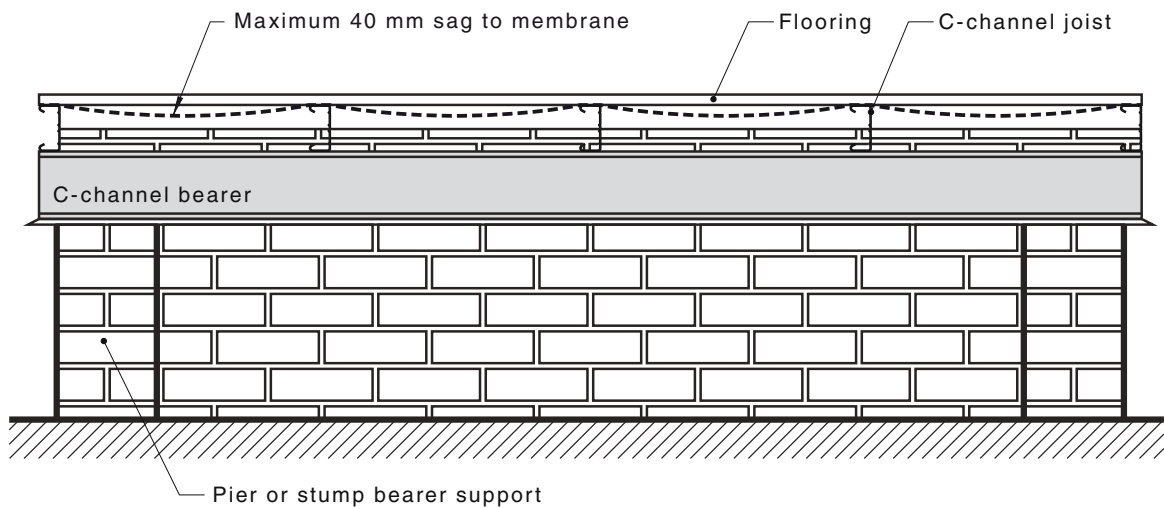

(b) Pliable building membrane installed under metal-framed floor (installed over joists)

FIGURE 3.11.1 (in part) INSTALLATION OF PLIABLE BUILDING MEMBRANES OVER AND UNDER FLOOR JOISTS

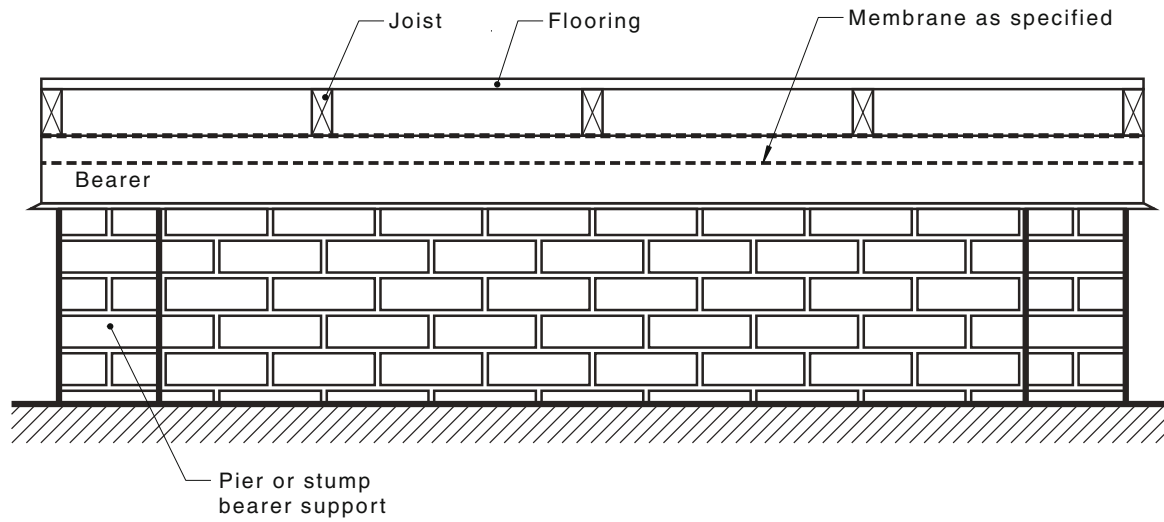

(c) Pliable building membrane installed under timber-framed floor (installed under joists)

FIGURE 3.11.1 (in part) INSTALLATION OF PLIABLE BUILDING MEMBRANES OVER AND UNDER FLOOR JOISTS

SECTION 4 PENETRATIONS

4.1 GENERAL

The pliable building membrane shall be cut neatly to allow penetration by chimneys, vents, pipes, cables and other services, as required.

4.2 THERMAL CONTROL

Where a pliable building membrane is installed as thermal control, penetrations shall be sealed to restrict air exchange between air cavities of either side of the membrane.

4.3 VAPOUR CONTROL AND AIR CONTROL

Where a pliable building membrane is installed as a vapour barrier or air barrier membrane, methods shall be used to restrict air exchange between air cavities of either side of the membrane in accordance with Clause 3.2.

4.4 WATER CONTROL

Where a pliable building membrane is installed as a water control membrane, penetrations shall be sealed with a pressure-sensitive and heat- and moisture-resistant tape.

NOTE: The membrane should divert the water away from the opening rather than towards it.

4.5 HOT FLUES

Where hot flues are installed, a pliable building membrane shall be installed with a space of 50 mm from the surface of any hot flue by sealing with a tape that is rated to be used at elevated temperatures, to avoid being a fire hazard.

NOTE: For a typical treatment of a pliable building membrane around a hot flue, see Figure 4.5.

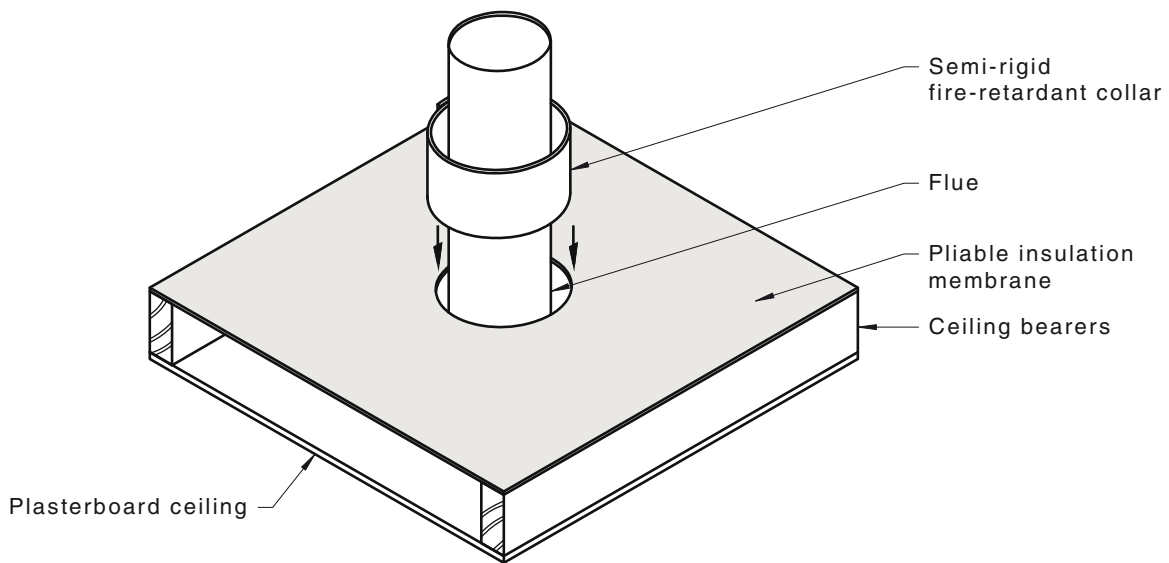

(a) Collar insert—Step 1

FIGURE 4.5 (in part) EXAMPLE TREATMENT OF PLIABLE BUILDING MEMBRANE AROUND HOT FLUE

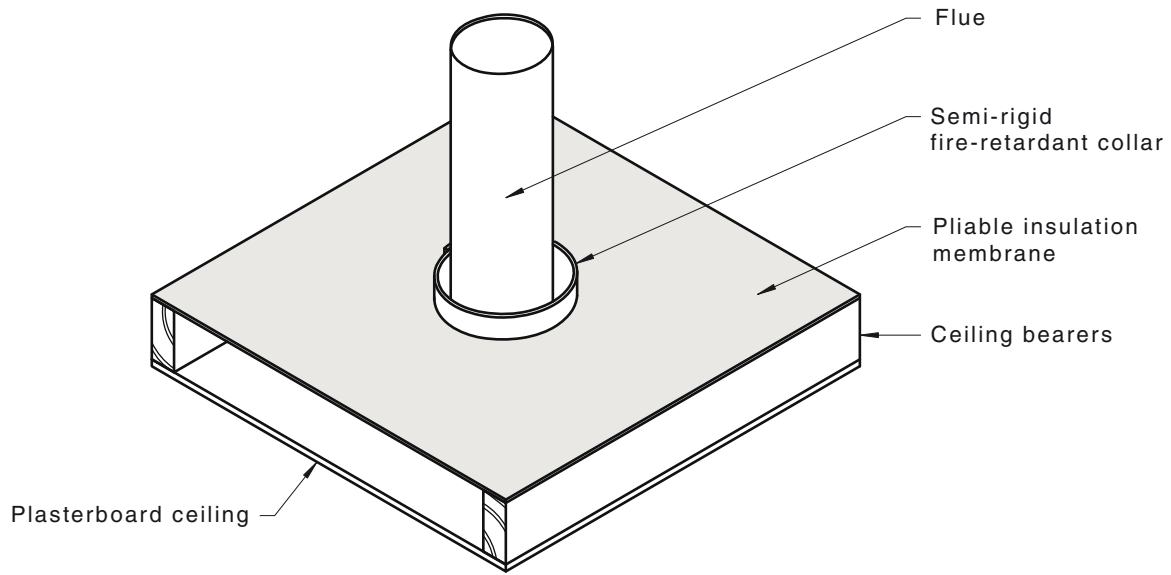

(b) Collar insert—Step 2

FIGURE 4.5 (in part) EXAMPLE TREATMENT OF PLIABLE BUILDING MEMBRANE AROUND HOT FLUE

4.6 RECESSED LUMINAIRES

Where a pliable building membrane is installed as a thermal control membrane in a ceiling with downlights and without luminaire barriers installed, penetrations shall be made in accordance with AS/NZS 3000. The minimum clearances shall be in accordance with Figure 4.6(A).

NOTE: For a typical treatment of a pliable building membrane around a downlight, see Figure 4.6(B).

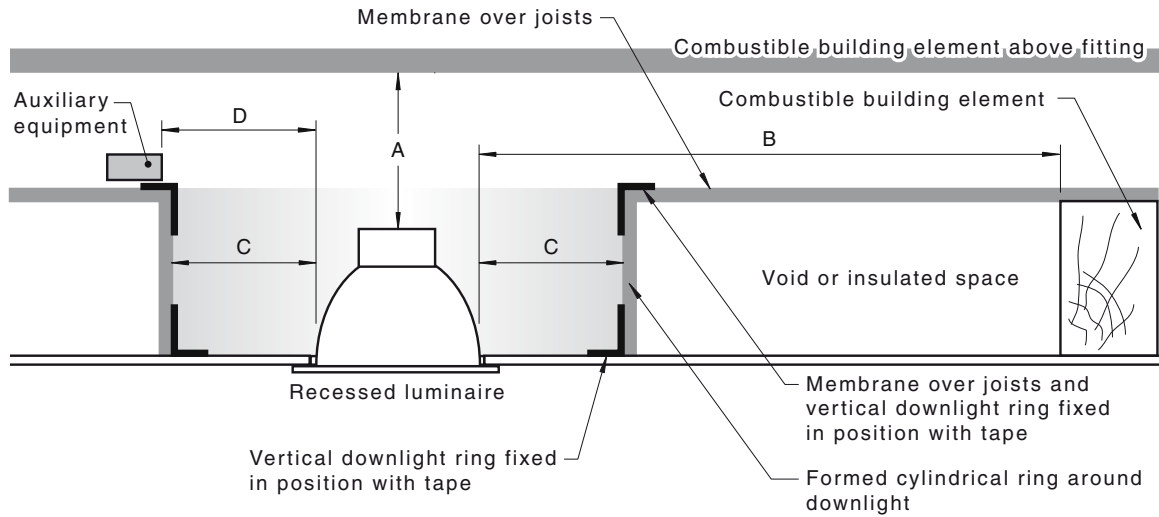

Dimension	Clearance
A Clearance above luminaire	200 mm
B Side clearance to combustible building element	200 mm
C Side clearance to bulk thermal insulation	50 mm
D Clearance to auxiliary equipment	50 mm

FIGURE 4.6(A) DEFAULT MINIMUM CLEARANCE FOR RECESSED LUMINAIRES

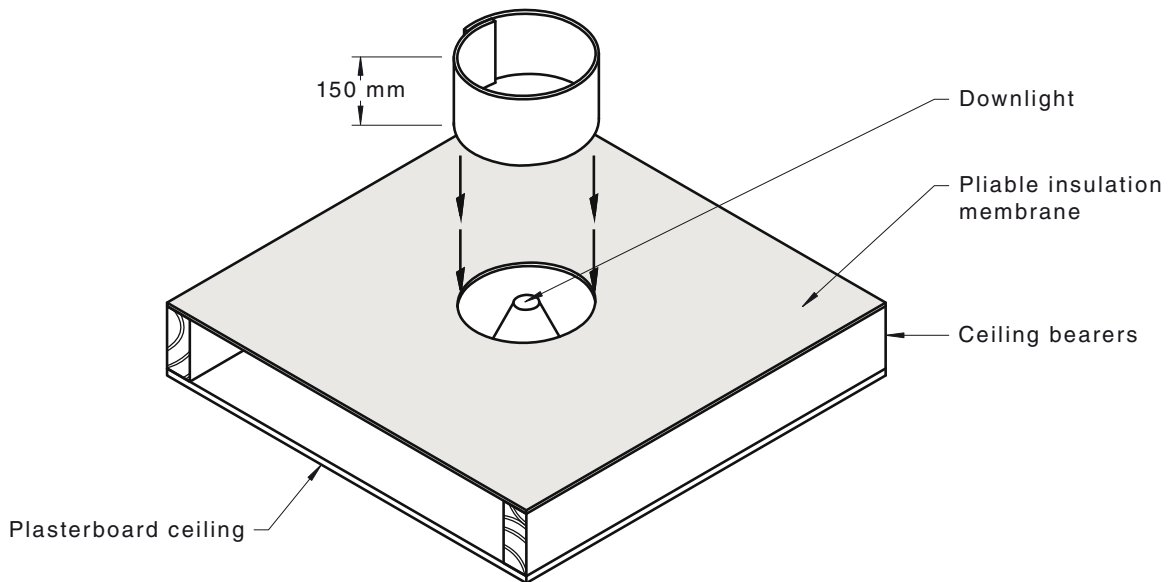

(a) Collar insert—Step 1

FIGURE 4.6(B) (in part) EXAMPLE TREATMENT OF PLIABLE BUILDING MEMBRANE AROUND DOWNLIGHT

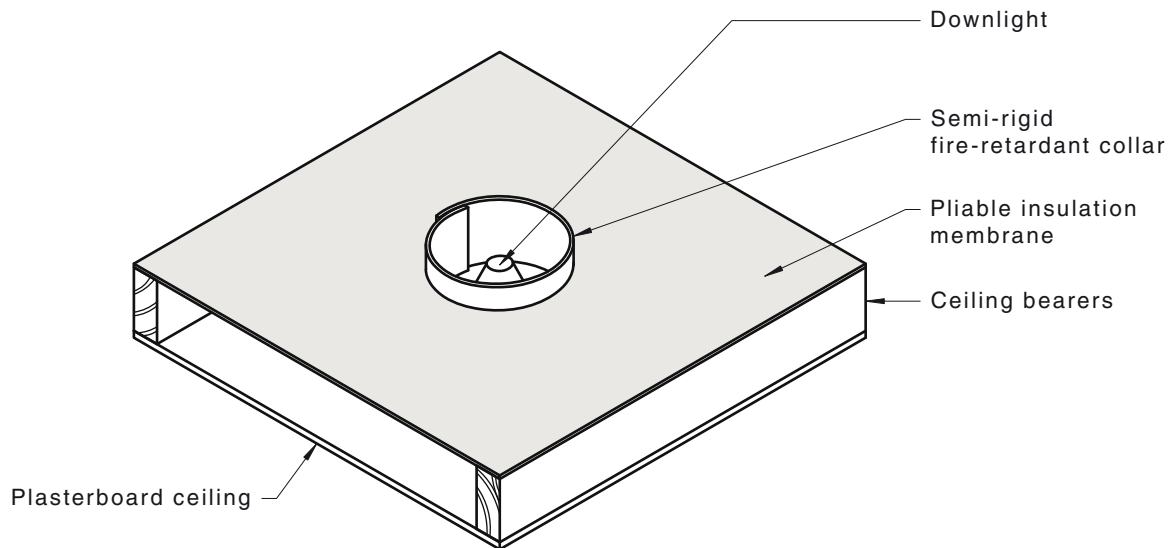

(b) Collar insert—Step 2

FIGURE 4.6(B) (in part) EXAMPLE TREATMENT OF PLIABLE BUILDING MEMBRANE AROUND DOWNLIGHT

4.7 WINDOWS, ROOF WINDOWS, SKYLIGHTS AND DOORS

At windows, doors and other openings, the pliable building membrane shall be cut and dressed into all sides of the opening to achieve the desired function of the membrane in accordance with Clauses 4.1, 4.2, 4.3 and 4.4.

The building membrane shall be installed to facilitate drainage to the building flashing.

NOTE: An example of membrane installation adjacent to flashing is shown in Figure 4.7, including the following:

- (a) Cutting the membrane—Illustration (a).
- (b) Folding the membrane back into the window reveal—Illustration (b).
- (c) Taping the exposed inside corners of the window reveal to hold the membrane in place—Illustration (c).

For thicker membranes greater than 1 mm, the membrane may be terminated at the outer edge of the frame and sealed using a pressure-sensitive and heat- and moisture-resistant tape.

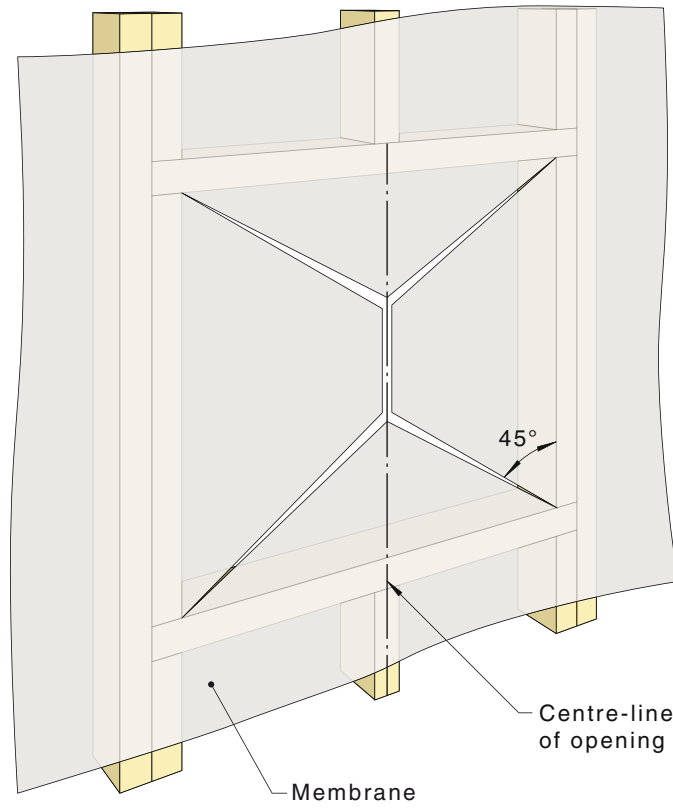

(a)

FIGURE 4.7 (in part) EXAMPLE OF WINDOW MEMBRANE TRIM DETAIL

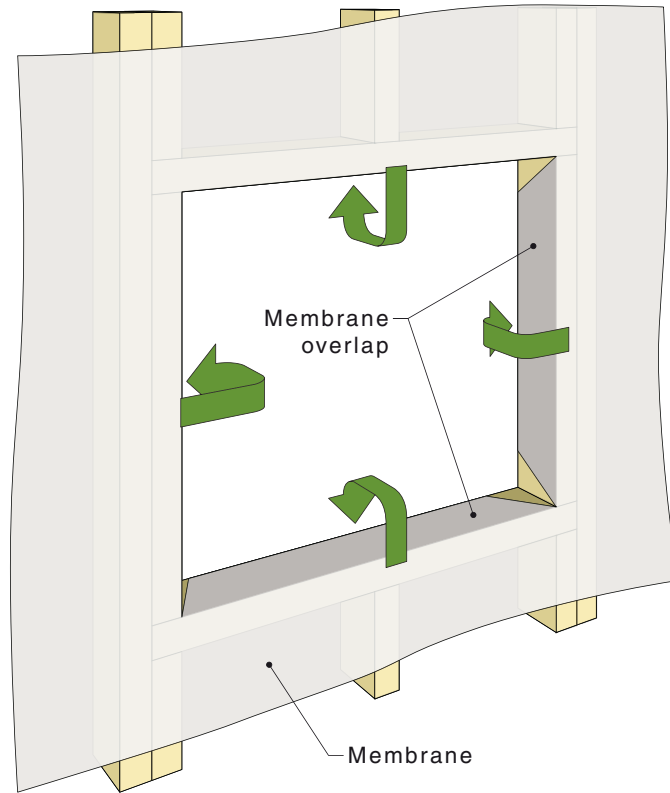

(b)

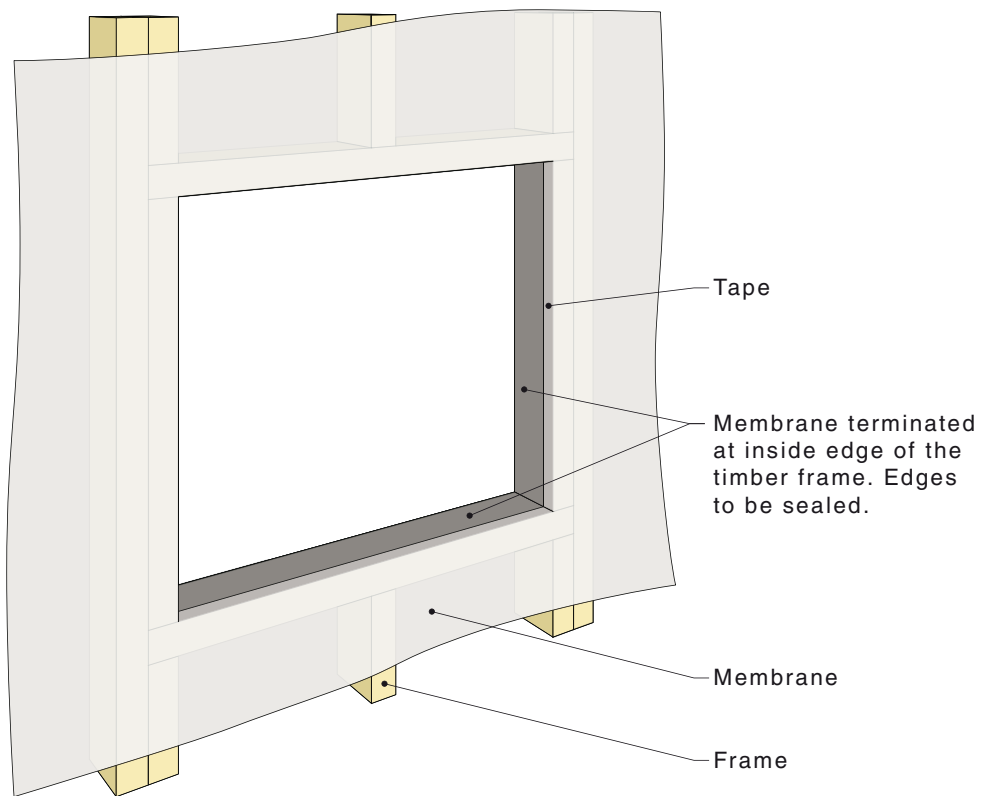

(c)

FIGURE 4.7 (in part) EXAMPLE OF WINDOW MEMBRANE TRIM DETAIL

APPENDIX A

SAFETY GUIDANCE FOR PLIABLE BUILDING MEMBRANE INSTALLATION

(Informative)

A1 GENERAL SAFETY GUIDANCE

Risk assessment and hazard control measures contained in federal, state and territory WHS legislation have to be followed.

Installation of membranes in existing structures may constitute an aggressive environment principally due to the elevated temperature, dust and higher risk of electrocution.

There may be specific requirements in WHS legislation and codes of practice regarding the installation of pliable building membranes, including electrically conductive insulation.

It should be ensured that installation of pliable building membrane does not impair the electrical safety of the building.

If the risks are found to be high, then no work should commence until these risks have been managed to a low level.

When installing reflective membranes in direct sunlight, special precautions should be taken against glare and the reflected solar radiation.

A2 ELECTRICAL SAFETY

A2.1 General

Pliable building membranes that are classified as electrically conductive conduct electricity. The installation process should ensure that these membrane do not become energized through contact with electrical wiring and equipment.

Prior to the installation of pliable membrane in an existing building or in a new building after electrical wiring or equipment has already been installed, a risk assessment should be conducted by a competent person to assess the electrical risk from the installation of pliable building membranes.

NOTES:

- 1 The risk assessment need not be done by a licensed electrician unless required by local regulations.
- 2 It is recommended that a record of the on-site assessment be kept for at least 5 years after the assessment is conducted.

A2.2 Electrical safety—Pliable building membrane on top of ceiling surfaces or ceiling joists and under subfloors

When insulation is to be installed in an existing building or in a new building after electrical wiring or equipment has already been installed across ceiling joists or under subfloors, the procedure should be as follows:

- (a) Before entering the ceiling space or commencing the installation, identify how to de-energize circuits located in the ceiling space, as follows:
 - (i) Before entering the ceiling, map the position of downlights and other appliances on a sketch plan of the building, as they may be difficult to see once in the ceiling.

- (ii) Check and note the location of electrical cables, electrical equipment and accessories in the area to be insulated.
- (iii) Check and note the location of any cabling that cannot be de-energized at the switchboard, e.g. mains supply and some solar PV wiring.

NOTES:

- 1 Unprotected electrical cables should not be positioned in locations where they are vulnerable to damage, such as over the tops of joists.
- 2 If warning signs on recessed luminaries are not present, then AS 3999 requires that they be installed on each access point to the ceiling.

- (b) Switch off the power to the work area that can be de-energized, and, if required, an alternative safe power supply for lighting and other work equipment.

NOTES:

- 1 Based on the risk assessment, further actions may be required to de-energize circuits located in the work area that cannot be de-energized from the switchboard.
- 2 Residual circuit devices (RCDs) provide added protection but should not be relied upon during installation.
- 3 Alternative lighting may include natural lighting.
- 4 The use of lock out arrangements and signage should be provided to avoid inadvertent re-energization of the circuit.

- (c) Where it is suspected or ascertained that electrically conductive insulation has been installed across the ceiling joists, the ceiling space should not be entered. Before any work in the ceiling space or under a subfloor commences, an electrical contractor should make an electrical safety assessment and issue a written statement confirming that they have inspected the installation and assessed the electrically conductive insulation to establish that it is not energized.

- (d) Risk assessment outcomes:

- (i) If the cabling or electrical equipment is suspected of being faulty, the owner should be advised.
- (ii) If the electrical insulation or equipment appears to be or is suspected of being faulty, the installation should not proceed until the installation is assessed and, if required, rectified and made safe by an electrician.
- (iii) If the installation is to proceed, all circuits that cannot be de-energized at the switchboard, e.g. mains supply and some PV solar wiring, should be identified.

NOTE: Based on the risk assessment, further actions may be required to de-energize circuits located in the work area that cannot be de-energized from the switchboard.

- (e) Equipment and fixings:

- (i) All equipment used for installing insulation should be designed to minimize the risk of electric shock. Only tools (knives, screwdrivers, etc.) that are non-conductive or have electrically insulated handles should be used. Clothing and any personal protective equipment worn should be non-conductive.
- (ii) If fasteners are required, non-metallic, non-conductive fasteners should be used.

- (f) During installation, when stapling or cutting insulation, there should be no cables or other electrical equipment in the vicinity.

NOTE: Cutting may be done on a kneeling board. It should not be performed with the insulation in place.

A2.3 Electrical safety inspection and testing

In a building of electrically conductive ceiling and subfloor insulation, before the start of the installation and on completion, a written statement should be obtained stating that—

- (a) the existing electrical installation in the ceiling structure and/or subfloor of the building has been inspected and tested; and
- (b) the existing electrical installation in the ceiling and/or subfloor structure of the building is electrically safe.

The written statement should be kept for a minimum of 5 years.

A2.4 Identification and marking of unprotected circuits

In a building of electrically conductive ceiling or subfloor insulation, before the start of the installation, a written statement should be obtained stating that each unprotected circuit located in the area to be insulated is identified and clearly marked.

An unprotected circuit should be clearly marked—

- (a) in a way that distinguishes the unprotected circuit from protected circuits located in the area to be insulated; and
- (b) at intervals of not more than 1 m, to the extent that this is reasonably practicable.

This written statement should explain the way in which unprotected circuits have been permanently marked to distinguish them from protected circuits.

If a protected circuit has been marked with durable high visibility tags, the certificate should explain this.

The written statement should be kept for a minimum of 5 years.

A2.5 Installation for unprotected circuits

Electrically conductive ceiling and subfloor membrane installed in a dwelling—

- (a) should not cover, in whole or in part, any unprotected circuit; and
- (b) should be installed at least 25 mm away from any unprotected circuit.

A2.6 Post installation

When the installation is complete, the correct operation of any electrical device should be checked again. If a fault is detected that was not present at the start of the work, then an electrician is needed to rectify the situation. If electrically conductive ceiling insulation has been installed, the electrician should be advised of this.

APPENDIX B

DURABILITY

(Informative)

B1 GENERAL

Membranes are specified for and installed in buildings to perform specific functions, for which they are tested and classified in accordance with AS/NZS 4200.1.

Durability means the capability of a building or its parts to perform a required function over a specified period of time.

Membranes may be affected by exposure during construction or while in service, or both, and their ability to resist any effects of this exposure is a measure of their durability.

The key matters to be considered for membranes are as follows:

- (a) Where the membrane is to be installed.
- (b) The range of service conditions it will be exposed to (pre-cladding and post cladding).
- (c) What function(s) it is expected to perform.
- (d) How long it is expected to last.

NOTES:

- 1 Some of these matters are interrelated.
- 2 The ABCB *Durability in Buildings including Plumbing Installations Handbook* contains guidance on the issue of durability within the context of the built environment. Aspects of durability relating to the objectives of safety, health and amenity are considered. It is intended as guidance for product manufacturers and appraisers for consideration when developing durability solutions.

B2 WHERE THE MEMBRANE IS TO BE INSTALLED

Membranes classified in this Standard and installed in accordance with this Standard are typically concealed and protected from the elements in roofs, ceilings, walls and floors.

B3 THE RANGE OF SERVICE CONDITIONS THE MEMBRANE WILL BE EXPOSED TO

Membranes may be exposed to aggressive environments. Factors that may need to be considered are as follows:

- (a) Temperature.
- (b) Solar radiation (UV).
- (c) Humidity.
- (d) Condensation.
- (e) Rainfall.
- (f) Wind and air flow.
- (g) Exposure to airborne salt.
- (h) Pollutants.
- (i) Chemical agents.

Membrane properties may respond differently to the anticipated service conditions, and the factors affecting each property need to be separately considered and assessed. Accelerated testing, field experience and judgement may all be involved in assessing whether particular products represent acceptable solutions.

B4 WHAT FUNCTION(S) THE MEMBRANE IS EXPECTED TO PERFORM

Membranes may be specified to perform one or several different functions. To perform those functions, the membrane may require several different material attributes or combinations of attributes.

B5 HOW LONG THE MEMBRANE IS EXPECTED TO LAST

The methodology for determining the appropriate design life for building components should include the following two factors:

- (a) The target design life of the building.
- (b) The accessibility of the component and the cost and practicality of repair or replacement.

B6 PARTICULAR TIME VULNERABILITIES OF MEMBRANE FUNCTIONS

When considering the design life of a membrane, the following key functions are potentially prone to degradation:

- (a) Vapour control.
- (b) Thermal control.
- (c) Air control.
- (d) Water control.

APPENDIX C
PROTECTION AGAINST CONDENSATION
(Informative)

C1 GENERAL

Pliable building membranes should be installed with due consideration of condensation and associated interaction with adjoining building materials.

The risk of condensation within the building could be reduced by the following:

- (a) Installation of vapour permeable membranes to the outside of the building frame in cold climates to allow migration of internal water vapour to the external environment.
- (b) Installation of vapour barrier membranes to the outside of the building frame in tropical climates to reduce the migration of external water vapour to the internal environment.

Consideration should be given to the need to include vapour control membranes, ventilation or additional ventilation, wetting and drying periods and annual moisture accumulation to reduce the potential for condensation.

NOTE: The ABCB, *Condensation in Buildings Handbook* contains guidance to assist architects, designers and builders in the assessment and the management of the risk of condensation and its consequences in the contemporary industry environment, and should be read in conjunction with the NCC provisions relating to damp and weatherproofing and to energy efficiency in all classes of buildings.

C2 MOISTURE ISSUES

Moisture gives rise to the following problems:

- (a) Surface condensation, which occurs when the temperature of a surface is at or below dew point temperature of water vapour in the air adjacent to the surface.
- (b) Mould growth on internal surfaces—Moulds and their spores are among the most significant causes of respiratory problems.
- (c) Interstitial condensation occurs within building cavities such as ceiling spaces and wall cavities, which can give rise to—
 - (i) corrosion of metal components;
 - (ii) decay of timber based components;
 - (iii) nail plate pull-out;
 - (iv) reduction of the performance of insulations; and
 - (v) concealed mould growth.

Minimization of these problems depends on—

- (A) appropriate thermal design of the building fabric for the given climate;
- (B) consideration of moisture production and ventilation within the building;
- (C) use of combinations of materials that allow for the possibility of storage and movement of moisture within the structure; and
- (D) use of materials and detailing appropriate to the location and use of the building.

C3 INTERNAL AND EXTERNAL MOISTURE

In order to design for condensation management, it is necessary to have an understanding of the building use, the local climate, construction type and ventilation.

The level of internal moisture generated is determined by building use, which is characterized by the following:

- (a) Number of occupants.
- (b) Cooking activity.
- (c) Showers.
- (d) Washing and drying.

This can be managed through the introduction of natural air and mechanical ventilation/extraction. The moisture content of the external air should be considered when using natural ventilation.

External moisture is determined by the climate. Historical data can be obtained from the Australian Bureau of Meteorology or weather conditions consistent with approved energy rating software may be used for design purposes.

C4 MECHANISMS OF MOISTURE MOVEMENT

C4.1 General

Moisture is transferred through a building element by a number of mechanisms. The relative importance of those mechanisms will be determined by the materials of which an element is composed and their configuration.

C4.2 Surface moisture transfer

Surface moisture transfer where airborne water vapour condenses onto a surface or where liquid water surface condensation is evaporated.

Most materials will take up water when exposed to moist air, the equilibrium quantity depending on the nature of the material, its pore structure and the relative humidity of the air. This phenomenon is important for the thermal conductivity of building and insulating materials. Very low porosity materials such as glass and metals may cause surface condensation at 60% relative humidity (RH) as opposed to high porosity materials such as bricks which will take high humidity close to 100% to cause surface condensation.

When managing moisture transfer in buildings, a systematic approach should be taken to ensure control of moisture movement.

C4.3 Diffusion

Most solid materials permit the diffusion of water vapour to some extent and, whenever there is a difference in the temperature and/or relative humidity across the material, a movement of water vapour takes place. This is analogous to the flow of heat through a material when subjected to a temperature difference.

ISO 13788 is the International Standard for condensation calculations based on vapour resistivity of building materials. Manufacturers' data sheets commonly quote vapour resistivity.

Product permeability may in some cases vary from international products depending on the manufacturing process, composition of raw materials and specialized coatings.

Vapour control layers as specified in the AS/NZS 4200 series are usually thin materials and it is more convenient to classify them by their vapour resistance than by their thickness and vapour resistivity.

Product manufacturers commonly state values for vapour resistances of membranes in data sheets. It should be noted that these values apply to undamaged membranes and the presence of any perforations may reduce the vapour resistance considerably.

C4.4 Air transfer

Moisture is transferred by air movement through gaps at the junctions between elements of the construction and through cracks within the elements. In a typical masonry wall with windows or other openings, the mass flow of moisture due to air movement through gaps can be as much as an order of magnitude greater than that produced by diffusion. This is especially true in the case of pitched roofs, where the moisture transfers are dominated by wind and stack driven air flows from the house into the ceiling space, through gaps in the ceiling and from the ceiling space to outside via installed ventilators and laps in the under tiling membrane.

C5 CONDENSATION RISK ASSESSMENTS

Condensation risk assessments are designed to assess the risk of interstitial condensation occurring within the building elements. The design should minimize or eliminate these risks so the materials' performance specified in the design should not be varied.

In well-sealed buildings, for energy efficiency, acoustics or bush fire resistance, a condensation risk assessment calculation is important.

Condensation risk analysis can be carried out according to ISO 13788 or conducted using an hourly analysis software program using weather conditions consistent with approved energy rating software. This assesses the risk of condensation within any configuration of cladding, air cavities, membranes, insulation, internal linings or any other additional construction layers.

BIBLIOGRAPHY

- AS
3959 Construction of buildings in bushfire-prone areas
3999 Bulk thermal insulation—Installation
- ISO
13788 Hygrothermal performance of building components and building elements—
Internal surface temperature to avoid critical surface humidity and interstitial
condensation—Calculation methods
- ABCB
Condensation in Buildings Handbook
Durability in Buildings including Plumbing Installations Handbook

AMENDMENT CONTROL SHEET**AS 4200.2:2017**

Amendment No. 1 (2018)

REVISED TEXT

SUMMARY: This Amendment applies to Clause 3.4.1.

Published on 29 June 2018.

NOTES

NOTES

NOTES

Standards Australia

Standards Australia develops Australian Standards® and other documents of public benefit and national interest. These Standards are developed through an open process of consultation and consensus, in which all interested parties are invited to participate. Through a Memorandum of Understanding with the Commonwealth Government, Standards Australia is recognized as Australia's peak non-government national standards body.

For further information visit www.standards.org.au

Australian Standards®

Committees of experts from industry, governments, consumers and other relevant sectors prepare Australian Standards. The requirements or recommendations contained in published Standards are a consensus of the views of representative interests and also take account of comments received from other sources. They reflect the latest scientific and industry experience. Australian Standards are kept under continuous review after publication and are updated regularly to take account of changing technology.

International Involvement

Standards Australia is responsible for ensuring the Australian viewpoint is considered in the formulation of International Standards and that the latest international experience is incorporated in national Standards. This role is vital in assisting local industry to compete in international markets. Standards Australia represents Australia at both the International Organization for Standardization (ISO) and the International Electrotechnical Commission (IEC).

Sales and Distribution

Australian Standards®, Handbooks and other documents developed by Standards Australia are printed and distributed under licence by SAI Global Limited.

For information regarding the development of Standards contact:

Standards Australia Limited
GPO Box 476
Sydney NSW 2001
Phone: 02 9237 6000
Email: mail@standards.org.au
Internet: www.standards.org.au

For information regarding the sale and distribution of Standards contact:

SAI Global Limited
Phone: 13 12 42
Email: sales@saiglobal.com



ISBN 978 1 76035 675 0